



**AGENDA**  
**DRAINAGE DISTRICT**  
**BOARD OF DIRECTORS**  
**June 2, 2015**  
**9:00 A.M.**

**NOTICE is hereby given in accordance with Chapter 551, Texas Government Code, that a SPECIAL MEETING of the Drainage District #1 Board of Directors will be held at the Edinburg Council Chambers, 415 W. University Drive, Edinburg, Hidalgo County, Texas. Discussion and possible action relating to the following business will be transacted:**

1. **Roll Call**
2. **Prayer**
3. **Open Forum**
4. **Approval of Consent Agenda**
5. Discussion on Hidalgo County Drainage District No. 1 Drainage projects, maintenance and operations
6. **AI -49879**
  - A.) Requesting approval to purchase six (6) new Caterpillar CT660S Dump Trucks from Holt Truck Centers through the Districts Membership with BuyBoard Contract No. 430-13 to include Extended Service Coverage and BuyBoard fees in the total amount of \$865,168.90.
  - B.) Requesting approval to purchase one (1) new Kobelco SK260LC Long Reach Excavator from Anderson Machinery through the Districts Membership with HGACBuy Contract No. EMO6-15 to include Extended Service Coverage in the total amount of \$226,318.00.
  - C.) Request approval of a Budget Amendment for 1.5 million to appropriate out of the Un-reserve Fund Balance of the 2007 and 2008 Bond Funds. The purpose of this funds is to provide assistance to the GLO East Lateral Project that under the direction of Urban County. This amount is in accordance to the inter-local agreement as approved by the Board on February 04, 2015
  - D.) Requesting approval to purchase one (1) new 2016 Ford Fusion from Silsbee Ford through the Districts Membership with BuyBoard Contract No. 430-13 to include BuyBoard fees in the total amount of \$18,577.75.

E.) Requesting approval to purchase one (1) R-10 Survey Equipment from Western Data Systems through the Districts Member with Department of Information Resources (DIR) Contract No. DIR-SDD-1796 in the amount of \$28,104.49.

F.) Requesting approval to accept bid and approval to execute Requirement Agreement with the lowest bidder meeting all specified requirements for RFB No.: HCDD1-15-008-05-13 "Gasoline, On & Off Highway Diesel Fuel" Gold Star Petroleum, Inc.

### **2013 BOND SERIES**

G.) Requesting approval to accept bid and approval to execute Construction Contract with the lowest bidder meeting all specified requirements for RFB No. 15-006-04-29A / GLO Contract No. 12-406-000-6453/DRS210068 "Pct. 1 - Tijerina Rural Development Drainage Improvements Project" Base Bid with Alternate No. 2 International Consulting Engineers (ICE) in the amount of \$240,152.00.

H.) Requesting approval of Work Authorization No. 7 in the amount of \$19,738.40 with L&G Engineering as it relates to H&H analysis and US 83 Relief Route Hydraulic Study for the La Joya Watershed Improvement Project.

7. **AI -49949** Discussion and approval of District's Construction Payment Guide and related Exhibits to become part of District's procedural forms when processing construction payments.
8. **AI -49950** Discussion and possible action to require addition of sub-consultants, with supporting documentation, by supplemental agreement in accordance to Article 14-Subcontracting and Assignments for professional engineering services, to include sub consultant's labor rates.
9. **Closed Session:**  
Board of Directors may go into Closed Session pursuant to Chapter 551, Texas Government Code, Sections 551.071 & 551.072 to discuss the following:
  - A. **Real Estate Acquisition**
  - B. **Pending and/or Potential Litigation**

- C. **AI -49951** Pending/Potential Litigation:  
Discussion of report submitted by the Lee Law Firm regarding their review, report and recommendations concerning the Agreement between Hidalgo County Drainage District No. 1 and Integ Corporation.

**10. Open Session:**

- A. **Real Estate Acquisition**

- B. **Pending and/or Potential Litigation**

- C. **AI -49952** Pending/Potential Litigation:  
Discussion, consideration and possible action related to the report submitted by the Lee Law Firm regarding their review, report and recommendations concerning the Agreement between Hidalgo County Drainage District No. 1 and Integ Corporation.

**11. Closed Session:**  
Board of Directors may reconvene into Closed Session for the discussion regarding the agenda items listed

**12. Open Session:**  
Board of Directors may reconvene into Open Session for the discussion regarding the agenda items listed

**13. Adjourn**

**AI -49879**

**6.**

**DRAINAGE DISTRICT**

Meeting Date: 06/02/2015

Submitted For: Jaime Salazar

Submitted By: Jaime Salazar, DRAINAGE  
DISTRICT

Department: DRAINAGE DISTRICT

---

Information

CAPTION

A.) Requesting approval to purchase six (6) new Caterpillar CT660S Dump Trucks from Holt Truck Centers through the Districts Membership with BuyBoard Contract No. 430-13 to include Extended Service Coverage and BuyBoard fees in the total amount of \$865,168.90.

B.) Requesting approval to purchase one (1) new Kobelco SK260LC Long Reach Excavator from Anderson Machinery through the Districts Membership with HGACBuy Contract No. EMO6-15 to include Extended Service Coverage in the total amount of \$226,318.00.

C.) Request approval of a Budget Amendment for 1.5 million to appropriate out of the Un-reserve Fund Balance of the 2007 and 2008 Bond Funds. The purpose of this funds is to provide assistance to the GLO East Lateral Project that under the direction of Urban County. This amount is in accordance to the inter-local agreement as approved by the Board on February 04, 2015

D.) Requesting approval to purchase one (1) new 2016 Ford Fusion from Silsbee Ford through the Districts Membership with BuyBoard Contract No. 430-13 to include BuyBoard fees in the total amount of \$18,577.75.

E.) Requesting approval to purchase one (1) R-10 Survey Equipment from Western Data Systems through the Districts Member with Department of Information Resources (DIR) Contract No. DIR-SDD-1796 in the amount of \$28,104.49.

F.) Requesting approval to accept bid and approval to execute Requirement Agreement with the lowest bidder meeting all specified requirements for RFB No.: HCDD1-15-008-05-13 "Gasoline, On & Off Highway Diesel Fuel" Gold Star Petroleum, Inc.

## 2013 BOND SERIES

G.) Requesting approval to accept bid and approval to execute Construction Contract with the lowest bidder meeting all specified requirements for RFB No.

15-006-04-29A / GLO Contract No. 12-406-000-6453/DRS210068 "Pct. 1 - Tijerina Rural Development Drainage Improvements Project" Base Bid with Alternate No. 2 International Consulting Engineers (ICE) in the amount of \$240,152.00.

H.) Requesting approval of Work Authorization No. 7 in the amount of \$19,738.40 with L&G Engineering as it relates to H&H analysis and US 83 Relief Route Hydraulic Study for the La Joya Watershed Improvement Project.

## BACKGROUND

---

Fiscal Impact

Attachments

Holt Truck Center

Anderson Machinery

Silsbee Ford

Western Data Systems

Gasoline Bid Tab

Pct. 1 Tijerina Bid Tab

WA No. 7 L&G

---

## Form Review

<b>Inbox</b>	<b>Reviewed By</b>	<b>Date</b>
Budget & Management	Veronica Ortiz	05/28/2015 04:31 PM
Final Approval	Monica Badillo	05/29/2015 04:47 PM
Form Started By: Jaime Salazar		Started On: 05/28/2015 09:29 AM
Final Approval Date: 05/29/2015		



CUSTOMER PROPOSAL

Customer Number:	562700	Date:	5/22/2015
Customer Name:	Hidalgo County Drainage District !	Proposal good through:	7/21/2015
<b>Description:</b>	<b>BUY BOARD CONTRAC # 430.13 Dump</b> <b>Truck with Caterpillar CX31 Automatic Transmission</b>		
Address: [?]	602 North Doolittle	Sales Representative	Mark Brunnemann - (956) 289-7636
City, State, Zip:	Edinburg, TX 78541	Registration Class:	NONE - Buyer will register unit
Contact Name:	Jaime Salazar	Requested G.V.W.R.	As per MSO or Title; no change
Contact Phone #:	956-292-7087		
Contact E-mail:	jaime.salazar@hcdd1.org		

Stock/ID Number:	TBD
VIN:	TBD
To be delivered on or about:	14 to 16 weeks from PO
Freight on Board (F.O.B.):	HOLT TRUCK CENTER - Edinburg, TX

Make:	Caterpillar
Model:	CT660
Year:	2016

	Per Unit	Total
Buy Board Base Price	\$105,098.61	\$630,591.66
Additional Vehicle and Accessories Description:	See Notes Below	See Notes Below
Optional Adds	\$17,271.09	\$103,626.54
Ox- Maverick 15' Dump Body	\$15,147.11	\$90,882.66
	\$0.00	\$0.00
	\$0.00	\$0.00
<b>NET Sales Price</b>	<b>\$137,516.81</b>	<b>\$825,100.86</b>
TRADE-IN ALLOWANCE	\$0.00	\$0.00
<b>Total Net Sales without Tax</b>	<b>\$137,516.81</b>	<b>\$825,100.86</b>
BALANCE OWED ON TRADE-IN	\$0.00	\$0.00
DOWN PAYMENT	\$0.00	\$0.00
FET - FEDERAL EXCISE TAX	\$0.00	\$0.00
FET - FEDERAL EXCISE TAX - BODY	\$0.00	\$0.00
LSC - STATE MOTOR VEHICLE SALES TAX	\$0.00	\$0.00
PST - 1% TERP TAX (1997 & NEWER)	\$0.00	\$0.00
TTL - TITLE & REGISTRATION	\$0.00	\$0.00
VIT - VEHICLE INVENTORY TAX	\$0.00	\$0.00
ESC - Extended Service Coverage GOLD 60 months/100,000 miles/10,000 hours, which ever	\$6,678.00	\$40,068.00
Out of State Vehicle Fee	\$0.00	\$0.00
<b>Sales Price:</b>	<b>\$144,194.82</b>	

Quantity:	6
-----------	---

**Total Sales Price: \$ 865,168.90**

Additional Vehicle and Accessories Description:



CUSTOMER PROPOSAL

Customer Number:	562700	Date:	5/22/2015
Customer Name:	Hidalgo County Drainage District I	Proposal good through:	7/21/2015

<b>Description:</b>	<b>BUY BOARD CONTRAC # 430.13</b>	<b>Dump</b>
	<b>Truck with Caterpillar CX31 Automatic Transmission</b>	

GOLD ESC+ 60 months/100,000 miles/10,000 hours Cost is \$8,370 Minus Caterpillar Credit of \$1,340 credit and an additional Holt credit in the amount of \$352 for a total price of \$6,678

**Special Titling & Registration Notes:**  
None

**Lienholder Notes:**  
None

**TRADE-IN NOTES**  
None

**DISCLAIMER:**  
Any order based on this Proposal subject to Customer executing Dealer's standard for Retail Purchase Order Incorporating above terms. Any documentary fees, state tax, title registration and license fees subject to adjustment and change. Actual F.E.T. to be paid by Dealer, subject to adjustment. Any F.E.T. variance will be responsibility of Dealer. Manufacturer has reserved the right to change the price to Dealer of any vehicle not currently in Dealer's stock, without notice to Dealer. If Quoted Vehicle's not currently in Dealers stock, Dealer reserves right to change Quotation Total to reflect any price increases from Manufacturer. This Proposal is based upon Dealer's current and expected inventory, which is subject to change. Dealer is not obligated to retain any specific vehicles in stock or maintain any specific inventory level. Dealer shall not be obligated to fulfill Proposal in event quoted vehicle's not in stock or available within requested delivery schedule at time Proposal accepted. Dealer shall not be liable for any delay in providing or inability to provide Quoted Vehicle's, where such inability or delay is due, in whole or in part, to any cause beyond the reasonable control of Dealer or is without the gross negligence or intended misconduct of Dealer. Above listed Trade Value based upon current appraisal of Trade Vehicle's. Dealer may adjust Trade Value of Trade Vehicle's to reflect changes in condition and/or mileage of Trade Vehicle's between date of current appraisal and acceptance of this Proposal by Customer.

**SELLER:** \_\_\_\_\_ **BUYER:** \_\_\_\_\_

  
Signature

\_\_\_\_\_  
Signature

Mark Brunnemann  
Printed Name:

\_\_\_\_\_  
Printed Name:

Sales Representative  
Title:

\_\_\_\_\_  
Title:



CUSTOMER PROPOSAL

Customer Number:	562700	Date:	5/22/2015
Customer Name:	Hidalgo County Drainage District 1	Proposal good through:	7/21/2015
Description:	<b>BUY BOARD CONTRAC # 430.13</b> <b>Truck with Caterpillar CX31 Automatic Transmission</b> <b>Dump</b>		
5/21/2015			
Date:		Date:	

Thank you for the opportunity to earn your business. We look forward to working with you on your business needs.

## Vendor Contract Information

[Back](#)

Search:

- All
- Vendor Discounts Only
- Catalog Pricing Only

### Refine Your Search:

- Vendors
- Holt CAT Truck Centers[X]
- Price Range
- Show all prices
- Category
- None Selected
- Contract
- None selected

### Additional Searches:

- [Search by Vendor](#)
- [Browse Contracts](#)
- [Instructional Materials](#)

**Vendor Name:** Holt CAT Truck Centers  
**Address:** 415 N. Walton Walker Loop 12  
 Irving, TX 75061  
**Phone Number:** (214) 596-7570  
**Email:** mark.mims@holtcat.com  
**Federal ID:** 74-1389993  
**Contact:** Mark Mims  
**Accepts RFQs:** Yes  
**Minority Owned Vendor:** No  
**Women Owned Vendor:** No  
**Contract Name:** Vehicles, Heavy Duty Trucks & Options  
**Contract#:** 430-13  
**Effective Date:** 12/01/2013  
**Expiration Date:** 11/30/2016  
**Service Fee:** Purchase order subject to a \$400 service fee  
**Payment Terms:** Net 30 days  
**Delivery Days:** 180  
**Shipping Terms:** Pre-paid and added to invoice  
**Freight Terms:** FOB Destination  
**Ship Via:** Common Carrier  
**Region Served:** All Texas Regions  
**States Served:** All States  
**Additional Info:** NOTE: As per the specifications for BuyBoard Proposal No. 430-13, and except for dealer fees as explained below, all vehicle fees (i.e. pre-deliver inspection, make ready, State Texas inspection, manufacturer destination fees, etc.) charged for any purchase from contract are included in the awarded vehicle base price(s). Vehicle fees not included in the awarded base price(s) are not allowed and should not appear on the awarded dealer's quote for a vehicle offered for purchase under the contract. The Cooperative service fee is not a "service fee" and is not included in the base pricing. Only those vendors whose awarded price is stated on the BuyBoard on a per mile basis may charge a vehicle delivery fee. The above information has been communicated to Cooperative members.  
**Quote Reference Number:** 430-13  
**Return Policy:** Case by case review  
**Additional Dealers:** See Extended Exceptions for dealer list.

### Contract Documents

- Proposal Documents:** [Click to view BuyBoard Proposal Documents](#)
- Extended Exceptions:** [Click to view Extended Contract Exceptions](#)
- Regulatory Notice:** [Click to view Bonding Regulatory Notice](#)



# CT660S SBA 6x4

Sales Proposal For:

HCD Dist 1 - **Cat CX31 AUTOMATIC**

Presented By:

**HOLT TEXAS LTD.**



May 21, 2015

Prepared For:  
HCD Dist 1 - Cat CX31 AUTOMATIC  
Reference ID: N/A

Presented By:  
HOLT TEXAS LTD.  
Mark Brunnemann  
3302 S W W WHITE RD  
SAN ANTONIO TX 78222 - 4843  
(210)648-8343

We are pleased to have the opportunity to offer the following proposal for the application you requested.

**Model Profile**  
**2016 CT660S SBA 6x4 (CF7AA)**

<b>APPLICATION:</b>	Light Aggregate
<b>MISSION:</b>	Requested GVWR: 54600. Calc. GVWR: 54600 Calc. Start / Grade Ability: 27.67% / 1.74% @ 55 MPH Calc. Geared Speed: 96.3 MPH
<b>DIMENSION:</b>	Wheelbase: 187.00, CA: 125.00, Axle to Frame: 69.00
<b>ENGINE, DIESEL:</b>	{CT 13} EPA 2010, SCR, 370 HP @ 1700 RPM, 1350 lb-ft Torque @ 1000 RPM, 2100 RPM Governed Speed, 370 Peak HP (Max)
<b>TRANSMISSION, AUTOMATIC:</b>	{Caterpillar CX31} 1st Generation Controls; 6 Speed, Includes Oil Level Sensor, with PTO Provision, for ON/OFF Highway
<b>CLUTCH:</b>	Omit Item (Clutch & Control)
<b>AXLE, FRONT NON-DRIVING:</b>	{Meritor MFS-14-143A} Wide Track, I-Beam Type, 14,600-lb Capacity
<b>AXLE, REAR, TANDEM:</b>	{Meritor MT-40-14X-4DFR-P} Single Reduction, 0.433"(11mm) Wall Housing Thickness, 40,000- lb Capacity, R Wheel Ends, With Lube Oil Pump Gear Ratio: 4.33
<b>CAB:</b>	Conventional
<b>TIRE, FRONT:</b>	(2) 12R22.5 G661 HSA (GOODYEAR) 484 rev/mile, load range H, 16 ply
<b>TIRE, REAR:</b>	(8) 11R22.5 G622 RSD (GOODYEAR) 497 rev/mile, load range G, 14 ply
<b>SUSPENSION, REAR, AIR, TANDEM:</b>	{Hendrickson HAS-402-55} 55" Axle Spacing; 40,000-lb Capacity, 9.5" Ride Height, With Shock Absorbers Mounted in Standard Location
<b>PAINT:</b>	Cab schematic 100KT Location 1: 9219, Winter White (Std) Chassis schematic N/A



Vehicle Specifications

May 21, 2015

**2016 CT660S SBA 6x4 (CF7AA)**

<u>Code</u>	<u>Description</u>	<u>F/R Wt</u> (lbs)	<u>Tot Wt</u> (lbs)	<u>List</u> (US DOLLAR)
CF7AA00	Base Chassis, Model CT660S SBA 6x4 with 187.00 Wheelbase, 125.00 CA, and 69.00 Axle to Frame.	9385/6587	15972	\$138,181.66
1570	TOW HOOK, FRONT (2) Frame Mounted	50/-10	40	\$372.38
1652	CROSSMEMBER, REAR Relocated to End of Frame	-21/102	81	\$234.14
1CDH	FRAME RAILS Heat Treated Alloy Steel (120,000 PSI Yield); 12.250" x 3.380" x 0.375" (304.8mm x 85.6mm x 9.5mm); 543.0" (13793mm) Maximum OAL	74/179	253	\$0.00
1LBC	BUMPER, FRONT Multi-piece Stainless Steel	0/0	0	\$0.00
	<u>Includes</u> : FOG LIGHT OPENING (2) and with Rectangular Hole for Step			
1WVS	WHEELBASE RANGE 183" (465cm) Through and Including 228" (580cm)	0/0	0	\$865.38
2ASM	AXLE, FRONT NON-DRIVING {Meritor MFS-14-143A} Wide Track, I-Beam Type, 14,600-lb Capacity	0/0	0	\$1,099.08
3ACP	SUSPENSION, FRONT, SPRING Multileaf, Shackle Type; 16,000-lb Capacity; Less Shock Absorbers	7/0	7	\$16.34
	<u>Includes</u> : SPRING PINS Threaded			
4091	BRAKE SYSTEM, AIR Dual System for Straight Truck Applications	0/0	0	\$0.00
	<u>Includes</u> : BRAKE LINES Color and Size Coded Nylon : DRAIN VALVE Twist-Type : DUST SHIELDS, FRONT BRAKE : DUST SHIELDS, REAR BRAKE : GAUGE, AIR PRESSURE (2) Air 1 and Air 2 Gauges; Located in Instrument Cluster : INVERSION VALVE Bendix SR-1 and Double Check Valve : PARKING BRAKE CONTROL Yellow Knob, Located on Instrument Panel : PARKING BRAKE VALVE For Truck : QUICK RELEASE VALVE Bendix On Rear Axle for Spring Brake Release: 1 for 4x2, 2 for 6x4 : SLACK ADJUSTERS, FRONT Automatic : SLACK ADJUSTERS, REAR Automatic : SWITCH, AUXILIARY Interrupter for Cab Clearance/Marker Lights (Blinks Lights with Headlight Switch in "ON" Position); Instrument Panel Mounted			
	<u>Notes</u> : The following features should be considered when calculating Rear GAWR: Rear Axles; Rear Suspension; Brake System; Brakes, Rear Air Cam; Brake Shoes, Rear; Special Rating, GAWR; Wheels; Tires.			
4619	TRAILER CONNECTIONS Four-Wheel, With Hand Control Valve and Tractor Protection Valve, for Straight Truck	2/0	2	\$306.70
	<u>Includes</u> : INVERSION VALVE Bendix SR-1 and Double Check Valve			



Vehicle Specifications

May 21, 2015

**2016 CT660S SBA 6x4 (CF7AA)**

<u>Code</u>	<u>Description</u>	<u>F/R Wt</u> (lbs)	<u>Tot Wt</u> (lbs)	<u>List</u> (US DOLLAR)
4732	DRAIN VALVE {Berg} Manual; With Pull Chain, for Air Tank  <u>Includes</u> : DRAIN VALVE Mounted in Wet Tank	0/0	0	\$0.00
4AZJ	AIR BRAKE ABS {Bendix AntiLock Brake System} Full Vehicle Wheel Control System (4-Channel) With Automatic Traction Control	0/0	0	\$163.04
4EBS	AIR DRYER {Bendix AD-9} With Heater  <u>Includes</u> : AIR DRYER LOCATION Inside Left Rail, Back of Cab	0/0	0	\$0.00
4ESX	BRAKE CHAMBERS, FRONT AXLE {Haldex} 20 SqIn	0/0	0	\$0.00
4EVL	BRAKE CHAMBERS, REAR AXLE {Haldex GC3030LHDHO} 30/30 Spring Brake	0/0	0	\$0.00
4JCJ	BRAKES, FRONT, AIR CAM S-Cam; 16.5" x 5.0"; Includes 20 Sq. In. Long Stroke Brake Chambers	0/0	0	\$0.00
4NDB	BRAKES, REAR, AIR CAM S-Cam; 16.5" x 7.0"; Includes 30/30 Sq.In. Long Stroke Brake Chamber and Spring Actuated Parking Brake	0/0	0	\$0.00
4SPM	AIR COMPRESSOR {Bendix BA-921 Head Unload} 15.9 CFM Capacity, Single Cylinder	0/0	0	\$0.00
5710	STEERING COLUMN Tilting and Telescoping	0/0	0	\$0.00
5PTB	STEERING GEAR (2) {Sheppard M-100/M-80} Dual Power	126/-13	113	\$1,047.23
5WBH	STEERING WHEEL {Caterpillar} 2-Spoke, 18" Diam., Dark Neutral, Leather Wrapped	0/0	0	\$0.00
7BJU	EXHAUST SYSTEM Switchback Horizontal Aftertreatment Device, Frame Mounted Right Side Under Cab; Includes Single Vertical Tail Pipe & Guard, Right Side, Cab Mounted	0/0	0	\$0.00
7WAZ	TAIL PIPE (1) Turnback Type, Non-Bright, for Single Exhaust	0/0	0	\$55.04
8000	ELECTRICAL SYSTEM 12-Volt, Standard Equipment  <u>Includes</u> : BATTERY BOX Aluminum : CIGAR LIGHTER Includes Ash Cup, Center Console Mounted : FUSES, ELECTRICAL SAE Blade-Type : HAZARD SWITCH Integral with Turn Signal Switch : HEADLIGHT DIMMER SWITCH Integral with Turn Signal Lever : HEADLIGHTS (2) Composite with Halogen Projector Beam : HORN, AIR Single, Chrome : HORN, ELECTRIC Single : PARKING LIGHT Integral with Front Turn Signal and Rear Tail Light : READING LIGHT, CAB (2) with Individual Switches; One Above Each Door : STARTER SWITCH Electric, Key Operated : STOP, TURN, TAIL & B/U LIGHTS Dual, Rear, Combination with Reflector : TURN SIGNAL FLASHER : TURN SIGNAL SWITCH Manual Cancelling with Lane Change Feature	0/0	0	\$0.00



Vehicle Specifications

May 21, 2015

2016 CT660S SBA 6x4 (CF7AA)

<u>Code</u>	<u>Description</u>	<u>F/R Wt</u> (lbs)	<u>Tot Wt</u> (lbs)	<u>List</u> (US DOLLAR)
	: TURN SIGNALS, FRONT Includes Integral Reflectors and Side Marker Lights; Fender Mounted : WINDSHIELD WIPER SWITCH 2-Speed with Wash and Intermittent Feature, Steering Column Mounted : WINDSHIELD WIPERS Single Motor, Electric, Cowl Mounted : WIRING, CHASSIS Color Coded and Continuously Numbered			
8554	TRAILER CONNECTION SOCKET 7-Way; Mounted at Rear of Frame	1/5	6	\$196.19
8653	HORN, AIR Single, Located Under Cab	5/0	5	\$0.00
8718	POWER SOURCE Cigar Type Receptacle without Plug and Cord	0/0	0	\$0.00
8GGN	ALTERNATOR {Bosch LH160} Brush Type, 12 Volt 160 Amp. Capacity, Pad Mount	0/0	0	\$0.00
8HAB	BODY BUILDER WIRING Back of Standard Cab at Left Frame or Under Extended or Crew Cab at Left Frame; Includes Sealed Connectors for Tail/Amber Turn/Marker/ Backup/Accessory Power/Ground and Sealed Connector for Stop/Turn	2/1	3	\$96.75
8MMJ	BATTERY SYSTEM {Caterpillar} (3) 12 Volt 2130CCA Total	0/0	0	\$0.00
8RMD	RADIO AM/FM/WB/Clock/3MM Auxiliary Input, with Multiple Speakers	1/0	1	\$329.67
8RMG	ANTENNA BASE (2) Single Function, (1) for CB and (1) for Entertainment Radio, Without Splitter, Separate Lead-Ins, With CB Antenna Mounted on Left Mirror and AM/FM Antenna Mounted on Right Mirror	0/0	0	\$0.00
8VUK	BATTERY BOX Aluminum With Plastic Cover, 18" Wide, 2, 3, or 4 Battery Capacity, Mounted Right Side Back of Cab	0/0	0	\$0.00
8WCK	POWER SOURCE, TERMINAL TYPE 2-Post	0/0	0	\$0.00
8WEZ	TURN SIGNAL SWITCH Self-Canceling	0/0	0	\$0.00
8WKU	BATTERY DISCONNECT SWITCH 200 Amp; Lever Operated, Locks with Padlock, Battery Box Mounted, Does Not Disconnect Charging Circuits, Disconnects Power to PDC	6/4	10	\$154.98
8WNH	RUNNING LIGHT (2) Daytime	0/0	0	\$0.00
8WXG	STARTING MOTOR {Mitsubishi Electric Automotive America 105P} 12-Volt, with Soft-Start	0/0	0	\$0.00
8WZC	BEACON LIGHTS (2) Cab Mounted, Includes Mounting Brackets, Wiring and Switch on Dash	21/1	22	\$424.73
8XAH	CIRCUIT BREAKERS Manual-Reset (Main Panel) SAE Type III With Trip Indicators, Replaces All Fuses Except For 5-Amp Fuses	0/0	0	\$88.69
9ASE	FRONT END Tilting Composite  <u>Includes</u> : GRILLE SURROUND Brushed Stainless Steel	0/0	0	\$0.00
9HAN	INSULATION, UNDER HOOD for Sound Abatement	0/0	0	\$143.62
9HBN	INSULATION, SPLASH PANELS for Sound Abatement	0/0	0	\$65.36



Vehicle Specifications

May 21, 2015

**2016 CT660S SBA 6x4 (CF7AA)**

<u>Code</u>	<u>Description</u>	<u>F/R Wt</u> (lbs)	<u>Tot Wt</u> (lbs)	<u>List</u> (US DOLLAR)
10060	PAINT SCHEMATIC, PT-1 Single Color, Design 100	0/0	0	\$0.00
10761	PAINT TYPE Base Coat/Clear Coat, 1-2 Tone	0/0	0	\$0.00
10WJM	GCWR RANGE , GCWR Equal to or Less than 66,000-lb, for Transmission Application Validation	0/0	0	\$0.00
11001	CLUTCH Omit Item (Clutch & Control)	-141/0	-141	\$0.00
12KXM	ENGINE, DIESEL {CT 13} EPA 2010, SCR, 370 HP @ 1700 RPM, 1350 lb-ft Torque @ 1000 RPM, 2100 RPM Governed Speed, 370 Peak HP (Max)	0/0	0	\$0.00
12THT	FAN DRIVE {Horton Drivemaster} Direct Drive Type, Two Speed With Residual Torque Device for Disengaged Fan Speed	0/0	0	\$0.00
12UND	FEDERAL EMISSIONS EPA, OBD and GHG Certified for Calendar Year 2015; CT13 Engines	0/0	0	\$8,000.00
12VBT	AIR CLEANER Single Element, Heavy Duty	0/0	0	\$0.00
12WBR	FAN OVERRIDE Manual; With Electric Switch on Instrument Panel, (Fan On With Switch On)	2/0	2	\$28.06
12WCX	HOSE CLAMPS, RADIATOR HOSES {Gates} Shrink Band Type	0/0	0	\$0.00
12WEG	COLD STARTING EQUIPMENT Automatic; With Engine ECM Control	0/0	0	\$0.00
12WTA	FAN DRIVE SPECIAL EFFECTS Fan Cooling Ring with Fan Shroud Effects, Engine Mounted	0/0	0	\$0.00
12WZE	EMISSION COMPLIANCE Federal, Does Not Comply With California Clean Air Idle Regulations	0/0	0	\$0.00
12XAV	RADIATOR Aluminum; Welded, Front to Back Down Flow System, 1429 SqIn, 740 SqIn CAC, 1099 SqIn 3 Core LTR	0/0	0	\$0.00
13CZZ	TRANSMISSION, AUTOMATIC {Caterpillar CX31} 1st Generation Controls; 6 Speed, Includes Oil Level Sensor, with PTO Provision, for ON/OFF Highway	370/93	463	\$20,835.86
	<u>Includes</u> : OIL FILTER, TRANSMISSION Mounted on Transmission : TRANSMISSION OIL PAN Magnet in Oil Pan			
13WCU	OIL COOLER, AUTO TRANSMISSION {Modine} Remote Mounted; For Use With Automatic Transmission Less Retarder	35/0	35	\$895.05
13WLM	TRANSMISSION OIL Synthetic; 63 thru 76 Pints	0/0	0	\$333.79
14862	PDL WARNING BUZZER Power Divider Lock	0/2	2	\$26.88
14899	SUSPENSION AIR CONTROL VALVE Pressure Release Control In Cab	4/4	8	\$146.02
14GVU	AXLE, REAR, TANDEM {Meritor MT-40-14X-4DFR-P} Single Reduction, 0.433"(11mm) Wall Housing Thickness, 40,000-lb Capacity, R Wheel Ends, With Lube Oil Pump . Gear Ratio: 4.33	0/0	0	\$0.00
	<u>Includes</u> : POWER DIVIDER LOCK Air Operated, Cab Control with Indicator Light in Cluster			



Vehicle Specifications

May 21, 2015

**2016 CT660S SBA 6x4 (CF7AA)**

<u>Code</u>	<u>Description</u>	<u>F/R Wt</u> (lbs)	<u>Tot Wt</u> (lbs)	<u>List</u> (US DOLLAR)
	: REAR AXLE DRAIN PLUG (2) Magnetic, For Tandem Rear Axle			
14UKZ	SUSPENSION, REAR, AIR, TANDEM {Hendrickson HAS-402-55} 55" Axle Spacing; 40,000-lb Capacity, 9.5" Ride Height, With Shock Absorbers Mounted in Standard Location	0/65	65	\$168.56
14WMJ	AXLE, REAR, LUBE {EmGard FE-75W-90} Synthetic Oil; 50 thru 64.99 Pints	0/0	0	\$313.04
15DYP	DEF TANK 9.5 U.S. Gal. 36.0L Capacity, Frame Mounted Outside Left Rail, Under Cab	0/0	0	\$0.00
15LKU	FUEL/WATER SEPARATOR {Racor} Fuel Pre-Filter and Filter Base, Includes Water-In-Fuel Sensor	0/0	0	\$0.00
15SHC	FUEL TANK Non-Polished Aluminum, 24" Diam., 100 U.S. Gal., 378 L Capacity Left Side, Under Cab.	21/17	38	\$237.40
16031	CAB Conventional	0/0	0	\$0.00
	<u>Includes</u>			
	: COAT HOOK, CAB Located on Rear Wall, Behind Passenger Seat			
	: CONSOLE, CENTER Plastic, Driver Convenience with a Cup and Change Holder, Ash Tray and Lower Storage Area			
	: DOME LIGHT, CAB (2) Driver and Passenger Dome Lights with Individual Switches, in Headliner			
	: DOOR CHECK STRAP (2) One Each Door			
	: GLASS, ALL WINDOWS Tinted			
	: GRAB HANDLE, CAB INTERIOR (1) "A" Pillar Mounted, Passenger Side			
	: GRAB HANDLE, EXTERIOR (2) Mounted Behind Driver and Passenger Doors			
	: INTERIOR SHEET METAL Upper Door (Above Window Ledge) Painted Exterior Color			
	: SKIN Riveted			
	: STEP (4) Two Steps Per Door			
16HBA	GAUGE CLUSTER English With English Electronic Speedometer	0/0	0	\$0.00
16HGL	GAUGE, OIL TEMP, REAR AXLE	0/0	0	\$163.40
16JPC	SEAT, DRIVER {National 2000 Model 295} Air Suspension, Intermediate Back, All Vinyl, 2 Arm Rests, Isolator, 7" Adjuster, 1 Chamber Lumbar, 2 Position Front Cushion Adjust, 3 Position Rear Cushion, 2-15 Degree Back Angle Adjust, Vinyl Suspension Cover	0/0	0	\$0.00
16RAC	SEAT, PASSENGER {National 2000 Model 292} Non Suspension, Intermediate Back, All Vinyl, 11 Degree Back Angle Adjustment	31/5	36	\$484.65
16SKV	MIRRORS (2) {Lang Mekra} Aero; Rectangular, 7.09" x 15.75" & Integral Convex Both Sides, 102" Inside Spacing, Breakaway Type, Thermostatically Controlled Heated Heads, Power Both Sides, Amber Lens Clearance Light LED, Turn Signals, Black Painted Finish Heads, Brackets & Arms	0/0	0	\$139.32



Vehicle Specifications

May 21, 2015

2016 CT660S SBA 6x4 (CF7AA)

<u>Code</u>	<u>Description</u>	<u>F/R Wt</u> (lbs)	<u>Tot Wt</u> (lbs)	<u>List</u> (US DOLLAR)
16VRT	HEATER, ENHANCED CIRCULATION {Bergstrom} Control, for Extreme Cold Weather Climates	0/0	0	\$0.00
16VTH	CAB INTERIOR TRIM Premium Level; for Caterpillar, Day Cab  <u>Includes</u> : "A" PILLAR COVER Molded Plastic : CAB INTERIOR TRIM PANELS Vinyl : CONSOLE, OVERHEAD Molded Plastic with Three Storage Pockets; One with Strap for CB Radio Mounting; Two with Netting, Courtesy Lights with Switches : COURTESY LIGHT (2) Driver and Passenger Door Mounted : DOOR TRIM PANELS Vinyl Upper with Power Locks and Windows, Upper and Lower Grab Handles, Both Sides : FLOOR COVERING Rubber, Black : HEADLINER Soft Padded Vinyl : HEATER BOX Metal, Painted Black : INSTRUMENT PANEL TRIM Vinyl : MIRROR, CONVEX, LOOK DOWN Black Finish; 6" x 10-1/4"; Located on Passenger Side : STORAGE POCKET, DOOR (2) Driver and Passenger Door : SUN VISOR (2) Vinyl with Molded Toll Ticket Retainer	0/0	0	\$0.00
16VZA	WINDOW, REAR 52.25" Wide	0/0	0	\$0.00
16WAK	WINDOW, POWER (2) in Left and Right Doors	0/0	0	\$0.00
16WBX	SEAT BELT All Belting Must Be Orange	0/0	0	\$37.73
16WJG	CAB DOOR LOCKS Power	0/0	0	\$0.00
16WKB	AIR CONDITIONER {International Blend-Air} With Integral Heater & Defroster	0/0	0	\$0.00
16WKS	WINDSHIELD Two Piece	1/0	1	\$179.96
16WLD	CAB REAR SUSPENSION {Link Z9079D1} Dual Frame Mounted Cab Rear Air Suspension; Includes Special Crossmember Assembly	0/0	0	\$0.00
16XWD	SUNSHADE, EXTERIOR Aerodynamic, Painted Roof Color; Includes Integral Clearance/Marker Lights	0/0	0	\$0.00
27DPL	WHEELS, FRONT DISC; 22.5" Painted Steel, 5-Hand Hole, 10-Stud (285.75MM BC) Hub Piloted, Flanged Nut, Metric Mount, 9.00 DC Rims; With .500" Thick Disc, Non-Standard Offset and Steel Hubs  <u>Includes</u> : PAINT IDENTITY, FRONT WHEELS White	68/0	68	\$245.10
28DTJ	WHEELS, REAR {Maxion 90541} DUAL DISC; 22.5" Painted Steel, 2 Hand Hole, 10 Stud (285.75MM BC) Hub Piloted, Flanged Nut, Metric Mount, 8.25 DC Rims; With Steel Hubs	0/447	447	\$51.96
29PAR	PAINT IDENTITY, FRONT WHEELS Disc Front Wheels; With Vendor Applied White Powder Coat Paint	0/0	0	\$20.64
29PAS	PAINT IDENTITY, REAR WHEELS Disc Rear Wheels; With Vendor Applied White Powder Coat Paint	0/0	0	\$77.40
29WLA	WHEEL BEARING, FRONT, LUBE {EmGard 50W} Synthetic Oil	0/0	0	\$21.50



Vehicle Specifications

May 21, 2015

2016 CT660S SBA 6x4 (CF7AA)

<u>Code</u>	<u>Description</u>	<u>F/R Wt</u> (lbs)	<u>Tot Wt</u> (lbs)	<u>List</u> (US DOLLAR)
7372138102	(8) TIRE, REAR 11R22.5 G622 RSD (GOODYEAR) 497 rev/ mile, load range G, 14 ply	0/40	40	\$1,470.32
7382158107	(2) TIRE, FRONT 12R22.5 G661 HSA (GOODYEAR) 484 rev/ mile, load range H, 16 ply	38/0	38	\$812.62
<b>Total of Product Features</b>				<b>\$178,530.24</b>
<b>Total Component Weight:</b>		<b>10088/7529</b>	<b>17617</b>	
<b>Total List Price Including Options:</b>				<b>\$178,530.24</b>

The weight calculations included in this proposal are an estimate of future vehicle weight. The actual weight as manufactured may be different from the estimated weight. Neither Caterpillar nor its suppliers shall be liable for any consequences resulting from any differences between the estimated weight of a vehicle and the actual weight.



Electronic Parameters Summary

May 21, 2015

2016 CT660S SBA 6x4 (CF7AA)
ENGINE, DIESEL (0012KXM)

ATTACHMENTS: 0016HBA (GAUGE CLUSTER) 0015LKU (FUEL/WATER SEPARATOR) 0012WEG (COLD STARTING EQUIPMENT) 0012THT (FAN DRIVE)

Table with 3 columns: Parameter, Value, UOM. Lists various engine and vehicle parameters such as Max Accelerator Vehicle Speed, Fuel Economy, and Idle Engine Speed.



Electronic Parameters Summary

May 21, 2015

**2016 CT660S SBA 6x4 (CF7AA)**

CC Max Vehicle Speed:7604	70	MPH
CC Min Vehicle Speed:7603	25.0000	MPH
AESC Control:7500	0, DISABLE FEATURE OR FUNCTION	N/A
AESC In-cab Mode:7502	2, VARIABLE ENGINE SPEED CONTROL SELECTED	N/A
AESC Min Engine Speed:7522	600.0	RPM
AESC Max Engine Speed:7508	1500.0	RPM
AESC Preset Engine Speed 1:7505	800.0	RPM
AESC Preset Engine Speed 2:7506	900.0	RPM
AESC Preset Engine Speed 3:7514	1000.0	RPM
AESC Preset Engine Speed 4:7515	1100.0	RPM
AESC Preset Engine Speed 5:7516	1200.0	RPM
AESC Preset Engine Speed 6:7517	1300.0	RPM
AESC Activate at Preset Speed:7528	0, NO PRESET PRESELECTION	N/A
AESC Ramp Up Rate:7507	100.00	RPM/SEC
AESC Ramp Down Rate:7524	100.00	RPM/SEC
AESC Bump Up/Down Step:7525	25.0	RPM
AESC In-cab Operator Interface:7503	0, NO (OFF) OR DISABLE	N/A
AESC Disable w/ Clutch Pedal:7510	1, ENABLE FEATURE OR FUNCTION	N/A
AESC Disable w/ Brake Pedal:7511	1, ENABLE FEATURE OR FUNCTION	N/A
AESC Accel Pedal Mode:7513	1, AESC OVERRIDDEN BY ACCELERATOR PEDAL	N/A
AESC Max Engine Load:7519	100.0000	%
AESC Control to Engine Load:7530	0, KICK OUT OF AESC ABOVE PROGRAMMED LIMIT	N/A
AESC Max Engine Load Time:7527	8	SEC
AESC Vehicle Speed Limit:7521	5.0000	MPH
AESC Max Mobile Veh Spd:7501	5	MPH
AESC Eng Spd Limit w/VSS Fault:7518	1500	RPM
AESC Force Fan On:9007	0, DISABLE FEATURE OR FUNCTION	N/A
AESC Park Brake Override:7534	1, ENABLE FEATURE OR FUNCTION	N/A
AESC Transfer Case Signal Mode:8910	0, DRIVELINE	N/A
AESC Splitshaft Veh SPD Dsply:9307	0, SPEED SENSOR LOCATED IN WHEEL RIM	N/A
AESC Remote Accel Pedal Enable:7504	0, DISABLE FEATURE OR FUNCTION	N/A
AESC Remote Accel Pedal Switch:8914	0, DISABLE FEATURE OR FUNCTION	N/A
AESC Accel Max Eng Spd Ovrdr:7520	1900.0	RPM
Rem Accelerator Switch Input:9929	1, SAE J1939 MULTIPLEXED	N/A
Preset Remote AESC Input Type:9932	0, DISCRETE (HARDWIRED) INPUT	N/A
Variable Remote AESC Input:9933	0, DISCRETE (HARDWIRED) INPUT	N/A
Rem Accelerator Position Input:9935	1, SAE J1939 MULTIPLEXED	N/A
Engine Protection Mode:7700	2, TWO WAY SHUTDOWN (OIL PRES, WATER TEMP)	N/A
Powertrain Protection Enable:7722	0, DISABLE FEATURE OR FUNCTION	N/A
Max Torque w/o Vehicle Speed:7712	1350.0000	LB-FT
Highest Gear of Low Range:7718	2	N/A
Highest Gear Rat of Low Range:7745	6.00	N/A
Highest Gear of Int. Range:7748	4	N/A
Highest Gear Rat of Int. Range:7746	4.00	N/A
Highest Gear of High Range:7749	6	N/A
Highest Gear Rat of High Range:7747	2.00	N/A
Max Torque in Low Gear Range:7713	1350.0000	LB-FT
Max Torque in Int. Gear Range:7750	1350.0000	LB-FT
Max Torque in High Gear Range:7751	1350.0000	LB-FT
VSS Anti-Tamper Max Eng Speed:7901	1200.0	RPM
Auxillary Shutdown Input Type:9931	0, DISCRETE (HARDWIRED) INPUT	N/A
Veh Speed Sensor Antitampering:7905	0, DISABLE FEATURE OR FUNCTION	N/A
Veh Overspd Threshold Level 1:7723	75.000000	MPH
Veh Overspd Threshold Level 2:7724	77.000000	MPH
Service Interval Enable	0, DISABLE FEATURE OR FUNCTION	N/A
Fuel Used Service Interval:9501	0	GALLONS
Engine Hour Service Interval:9502	0	HOURS
Veh Distance Service Interval:9503	0	MILES
Service Soon Percent to Notify:9507	90	%



Electronic Parameters Summary

May 21, 2015

**2016 CT660S SBA 6x4 (CF7AA)**

Customer Unit Number:6605	0	N/A
Hard Braking Incident Counter:8904	1, ENABLE FEATURE OR FUNCTION	N/A
Hard Braking Decel Threshold:8905	7.40	MPH/SEC
Vehicle Over-speed Indicator:7754	0, FEATURE OR FUNCTION IS DISABLED	N/A
Customer Password:8700	00000000	N/A

These Electronic Parameters have been successfully finalized



2016 CT660S SBA 6x4 (CF7AA)  
ENGINE/TRANSMISSION MATCHING

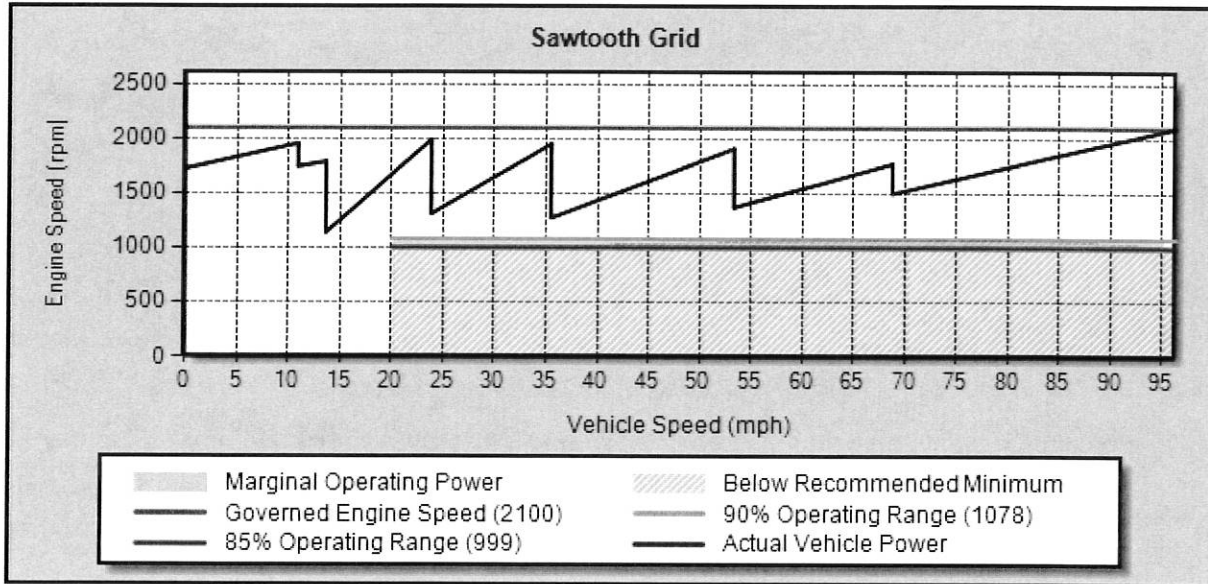

Sawtooth Details

Gear	Trans Ratio	Upshift Power Avail		Govern Power Avail		Peak Power Comparison			Warn Msg
		Veh Spd (MPH)	Eng Spd (RPM)	Veh Spd (MPH)	Eng Spd (RPM)	Gear Step (%)	85% Range (%)	90% Range (%)	
1C	4.40	0.0	1725	10.9	1955	N/A	110	95	
2C	2.33	10.9	1745	13.6	1789	N/A	110	95	
2L	2.33	13.6	1138	23.8	1992	N/A	110	95	
3L	1.53	23.8	1309	35.5	1952	N/A	110	95	
4L	1.00	35.5	1273	53.3	1910	N/A	110	95	
5L	0.72	53.3	1371	68.8	1773	N/A	110	95	
6L	0.61	68.8	1501	96.3	2100	N/A	110	95	

@ - WHEELSLIP CAN OCCUR AT THE GRADE SHOWN. THE VEHICLE IS CAPABLE OF INCREASED GRADEABILITY IF MORE WEIGHT IS PLACED ON THE DRIVE AXLES.



2016 CT660S SBA 6x4 (CF7AA)  
STEADY STATE PERFORMANCE

Performance Results	Gear	Veh Spd (mph)	Eng Spd (rpm)	Fuel Econ (mpg)	Grade (%)	Notes
LEVEL ROAD MAXIMUM SPEED	6L	81.5	1778	4.37	0.00	
HI GEAR SPEED @ RATED RPM	----	----	----	----	----	
55.0 MPH STEADY-STATE	6L	55.0	1199	7.40	1.74	
TYPICAL OPERATING SPEED	6L	70.0	1526	5.60	0.84	- Calculated Grade Ability/Fuel Economy

VEHICLE ORDER CODING ERRORS MAY RESULT IF THE "LEVEL ROAD MAX SPEED" VALUE EXCEEDS THE "HI GEAR SPEED @ RATED RPM" AND IS USED AS THE ENGINE PROGRAMMABLE VEHICLE SPEED LIMIT.

IF THE RESULTS CONTAIN " ----", VEHICLE CANNOT ATTAIN THAT SPEED.

IF THE RESULTS CONTAIN "\*\*\*\*\*", THE ENGINE USED DOES NOT HAVE A FUEL MAP. FUEL ECONOMY CANNOT BE PREDICTED.

Recommendations / General Information

IDLE FUEL RATE : 0.80 GALS/HR @ 600.0 RPM  
TORQUE CONVERTER : TC-427 STALL RATIO: 2.32

Fuel Economy Route: Normal Route - City, Suburban, and Highway

Key Fuel Economy Information	City	Suburban	Highway	Notes
MILES PER GALLON	4.91	6.94	6.98	
AVERAGE MPH	19.0	39.8	54.6	
MISSION MINUTES	29.81	52.00	173.36	

IF THE RESULTS CONTAIN "\*\*\*\*\*", THE ENGINE USED DOES NOT HAVE A FUEL MAP. FUEL ECONOMY CANNOT BE PREDICTED.



2016 CT660S SBA 6x4 (CF7AA)  
GRADEABILITY PERFORMANCE

Enroute - Full Throttle Upshift Performance

Gear	Trans Ratio	Veh Spd (mph)	Eng Spd (rpm)	Whl Pwr (hp)	Grade (%)	Warn Notes Msg
1C	4.40	0.0	1725	0.00	51.28	@ STALL
		5.1	1727	237.56	32.46	70% EFF
		6.7	1774	270.24	27.67	80% EFF
		10.9	1955	268.58	16.31	
2C	2.33	10.9	1745	253.59	15.33	
		13.6	1789	277.90	13.26	
2L	2.33	13.6	1138	266.61	12.67	
		23.8	1992	305.23	7.83	
3L	1.53	23.8	1309	301.08	7.71	
		35.5	1952	314.38	4.89	
4L	1.00	35.5	1273	298.46	4.58	
		53.3	1910	326.24	2.55	
5L	0.72	53.3	1371	304.70	2.27	
		68.8	1773	332.57	1.10	
		69.9	1800	333.23	1.00	
		74.1	1907	318.14	0.50	
6L	0.61	77.8	2004	294.85	0.00	LEVEL ROAD
		67.8	1478	313.32	1.00	
		68.8	1501	315.22	0.92	
		74.8	1631	324.47	0.50	
		81.6	1779	330.59	0.00	LEVEL ROAD
		96.3	2100	262.21	-1.69	RATED RPM

STARTING / TOP GEAR PERFORMANCE

Gear	Trans Ratio	Veh Spd (mph)	Eng Spd (rpm)	Whl Pwr (hp)	Grade (%)	Warn Notes Msg
1C	4.40	0.0		0.00	51.28	@ STALL
		6.7		270.24	27.67	80% EFF - Calculated Start Ability

@ - WHEELSLIP CAN OCCUR AT THE GRADE SHOWN. THE VEHICLE IS CAPABLE OF INCREASED GRADEABILITY IF MORE WEIGHT IS PLACED ON THE DRIVE AXLES.

THE TRANSMISSION WAS SIMULATED IN PERFORMANCE OPERATING MODE.



2016 CT660S SBA 6x4 (CF7AA)  
ACCELERATION PERFORMANCE RESULTS

Acceleration Performance Grid

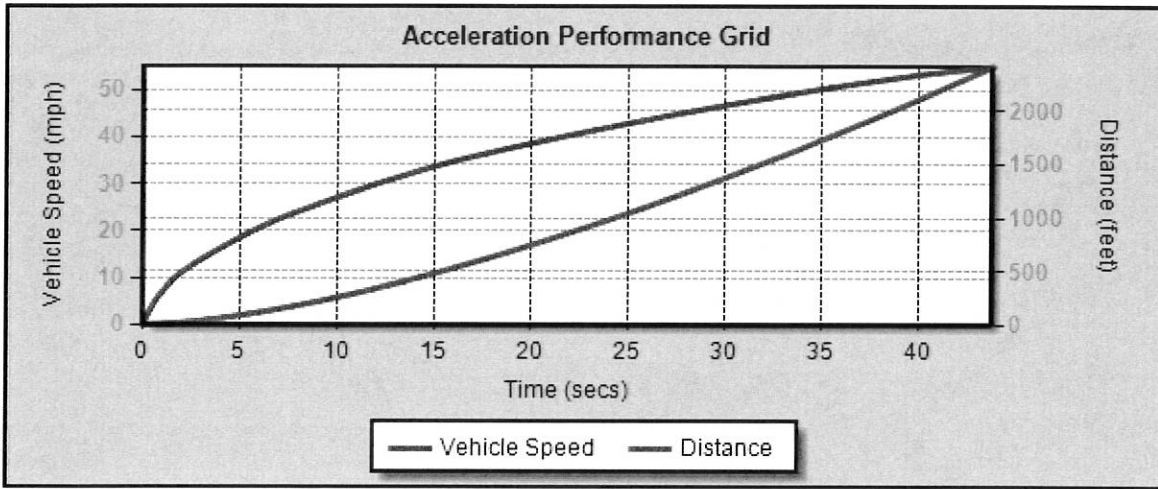

Acceleration Performance: TIME TO ACCELERATE ON A GRADE TO 55.0 (MPH) IS 43.84 (SECS)

Acceleration Performance Details

Gear	Time (secs)	Distance (feet)	Speed (mph)	Notes
1C	0.14	0.1	1.0	
	0.26	0.4	2.0	
	0.38	0.8	3.0	
	0.51	1.5	4.0	
	0.65	2.4	5.0	
	0.81	3.7	6.0	
	1.00	5.4	7.0	
	1.20	7.7	8.0	
	1.42	10.5	9.0	
	1.67	14.0	10.0	
2C	1.93	17.9	10.9	
	2.28	23.7	11.9	
	2.63	30.1	12.9	
	2.89	35.2	13.6	
2L	3.30	43.7	14.6	
	3.72	52.9	15.6	
	4.14	62.9	16.6	
	4.58	73.9	17.6	
	5.04	86.0	18.6	
	5.51	99.3	19.6	
	6.00	113.8	20.6	
	6.52	129.7	21.6	
	7.06	147.5	22.6	
	7.67	168.0	23.6	
3L	7.80	172.7	23.8	
	8.45	195.5	24.8	
	9.10	220.0	25.8	
	9.78	246.0	26.8	
	10.47	273.8	27.8	
	11.19	303.4	28.8	
	11.92	335.0	29.8	
12.68	368.6	30.8		



Performance TCAPE Summary

May 21, 2015

2016 CT660S SBA 6x4 (CF7AA)

Gear	Time (secs)	Distance (feet)	Speed (mph)	Notes
	13.45	404.4	31.8	
	14.26	442.6	32.8	
	15.11	484.0	33.8	
	16.01	529.6	34.8	
4L	16.68	563.6	35.5	
	17.72	618.9	36.5	
	18.79	676.7	37.5	
	19.88	737.4	38.5	
	20.99	801.1	39.5	
	22.13	868.1	40.5	
	23.30	938.4	41.5	
	24.50	1012.2	42.5	
	25.73	1089.7	43.5	
	26.99	1171.2	44.5	
	28.29	1256.9	45.5	
	29.63	1347.0	46.5	
	31.00	1441.8	47.5	
	32.42	1541.7	48.5	
	33.89	1647.2	49.5	
	35.41	1758.9	50.5	
	37.02	1878.9	51.5	
	38.73	2009.2	52.5	
5L	40.11	2116.3	53.3	
	42.22	2282.8	54.3	
	43.84	2412.8	55.0	



2016 CT660S SBA 6x4 (CF7AA)
REQUIRED TCAPE INFORMATION

TCAPE Factors For Vehicle

Table with 2 columns: Factor Name and Value. Includes items like Selected Rear Axle Gear Ratio(s), Vehicle Vocation, Enroute PTO, Transmission Mode, Fuel Economy Route, ID Wheel Slip Conditions, Engine Fan Type, Road Surface Type, Parked PTO, Road Governor/Cruise Ctrl, Acceleration Grade (%), Alternator (A), Weight on Drive Axle (LBF), Frontal Area (FT2), Air Compressor (HP), Vehicle Width (IN), Vehicle Height (IN), Steering Gear (HP), Air Conditioner (HP), Acceleration Vehicle Spd (MPH), Speed Limit on Route (MPH), Relative Drag Coefficient, TIRE, FRONT, and TIRE, REAR.

Components

Table with 2 columns: Component ID and Description. Lists various vehicle components such as AXLE, FRONT NON-DRIVING, AIR COMPRESSOR, STEERING GEAR, ALTERNATOR, ENGINE, DIESEL, FAN DRIVE, TRANSMISSION, AUTOMATIC, AXLE, REAR, TANDEM, CAB Conventional, AIR CONDITIONER, SUNSHADE, EXTERIOR, and TIRE, REAR and FRONT.

TCAPE HAS BEEN DESIGNED TO GIVE ECONOMY AND PERFORMANCE PREDICTIONS WHICH HAVE BEEN SHOWN TO BE TYPICAL FOR MOST OPERATIONS. HOWEVER, DUE TO OPERATING CONDITIONS, DRIVER INFLUENCES, AND OTHER FACTORS, YOUR RESULTS MAY VARY FROM THOSE PREDICTED. ALSO, BECAUSE OF FUEL MAPPING PROCEDURES USED BY VARIOUS ENGINE MANUFACTURERS, COMPARISONS OF FUEL ECONOMY RESULTS FOR DIFFERENT BRANDS OF ENGINES MAY VARY FROM THOSE SHOWN.

NEITHER CATERPILLAR NOR ITS SUPPLIERS SHALL BE LIABLE FOR ANY LOSS OF PROFITS, LOSS OF USE, INTERRUPTION OF BUSINESS OR INDIRECT, SPECIAL, INCIDENTAL OR CONSEQUENTIAL DAMAGES OF ANY KIND THAT ARE INCURRED BY DEALER OR BY DEALER'S CUSTOMERS AS A RESULT OF RELIANCE ON TCAPE, WHETHER THE CLAIM IS IN CONTRACT, TORT (INCLUDING NEGLIGENCE), STRICT LIABILITY OR OTHERWISE.



**Turning Radius Summary**

May 21, 2015

**2016 CT660S SBA 6x4 (CF7AA)**

Series: CAT  
 Model: CF7AA  
 Description: CT660S SBA 6x4  
 Model Year: 2016

**Calculation Factors**

Wheelbase: 187  
 Front Axle: 0002ASM  
 Description: AXLE, FRONT NON-DRIVING, {Meritor MFS-14-143A} Wide Track, I-Beam Type, 14,600-lb Capacity  
 Front Wheel: 0027DPL  
 Description: WHEELS, FRONT, DISC; 22.5" Painted Steel, 5-Hand Hole, 10-Stud (285.75MM BC) Hub Piloted, Flanged Nut, Metric Mount, 9.00 DC Rims; With .500" Thick Disc, Non-Standard Offset and Steel Hubs  
 Front Tire: 07382158107  
 Description: TIRES, 12R22.5 G661 HSA (GOODYEAR) 484 rev/mile, load range H, 16 ply  
 Steering Gear: 0005PTB  
 Description: STEERING GEAR, (2) {Sheppard M-100/M-80} Dual Power

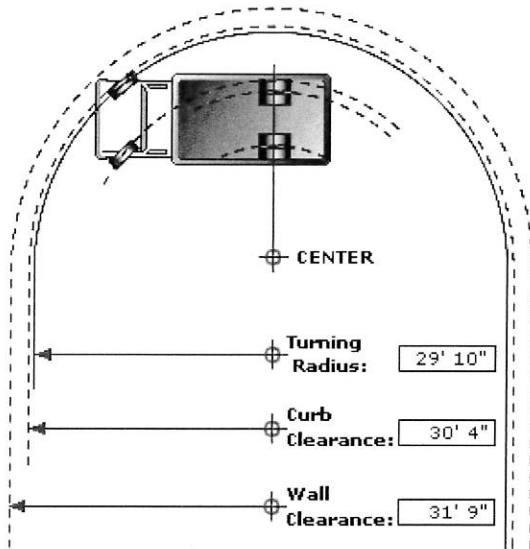

**Turning Radius Statistics**

General Information

Inside Turn Angle: 40 Degrees  
 Radial Overhang: 23

Axle Information

KingPin Inclination: 6.25 Degrees  
 KingPin Center: 71.5

**Turning Radius - Curb View**

C - Curb Contact Length: 16.16  
 CI - Curb Clearance Increment: 6.16  
 CR - Curb Clearance Radius: 30'4"  
 CH - Curb Height: 6"  
 TR - Turning Radius: 29'10"  
 TW - Tire Width: 11.60

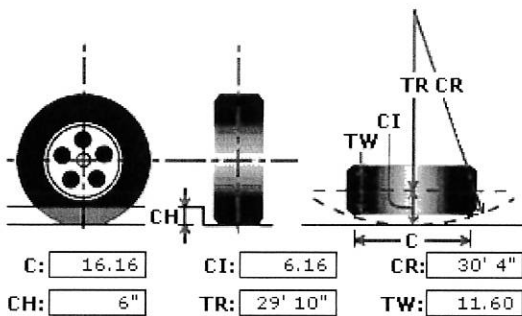

\* All Measurements are in inches, unless otherwise specified.



Turning Radius Summary

May 21, 2015

**2016 CT660S SBA 6x4 (CF7AA)**

This information is based on engineering information available at this time. Actual figures may vary. Neither Caterpillar nor its suppliers can accept liability for consequences due to this variance.



# Quote Response Form

**TRUCK BODIES & EQUIPMENT INTERNATIONAL, Inc.**  
Ox Bodies | Crysteel | DuraClass | Rugby | J-Craft | Hardee

TBEI - Ox Bodies  
719 Columbus Street East  
PO Box 886  
Fayette AL 35555  
800-844-2519

**End User:** HIDALGO COUNTY DRA  
**Customer:** 104731  
Mark Brunnemann  
HOLT TRUCK CENTERS  
1320 SOUTH 25TH STREET  
EDINBURG TX 78539  
USA

**Phone:** 956-289-7636  
**Fax:** 956-383-6819

**Taken By:** Jennifer Reed

Estimate	Terms	Quote Date	Expiration Date	Salesperson	Customer Currency
FA00062186	Net 30 Days	3/11/2015	4/10/2015	HOWARD, CHIP	USD

UM	Quantity	Item	Unit Price	Extended Price
EA	1.000	1783466 MV851500-1415YD-63130-56/42/50STR-S	9,976.11	9,976.11

Yardage 14/15

Body: Maverick  
 Body: 15' MAVERICK  
 Hoist Model: 1248910-63130  
 Frame Style: 2x8 RT w/1.5x3 RT xmem on 12 CL (framele  
 Rear Style: Straight  
 Front Exhaust Notch: No  
 Front Height: 56"  
 Side Height Front: 42" 10 Gauge  
 Side Height Rear: 42"  
 Rear Height: 50" 7 Gauge  
 Front Material: 10 Gauge  
 Floor Material: 7 Gauge  
 Cabshield Style: Standard  
 Cabshield Projection: 24"  
 Cabshield Width: 85"  
 Tarp Style: Electric - Mountain Tarp  
 Tailgate Type: Standard  
 Sealed Tailgate: No  
 Coal Chute: None  
 Tailgate Operation: Air  
 Tailgate Bracing Style: 1 Horizontal (TG height 37" to 54")  
 Horizontal Side Brace: No  
 Side Top Rail Style: Standard 4x4 11 GA  
 Tread Plate Aluminum Bottom Rail: No  
 Polished Aluminum Insulation Side/Front : No  
 Dump Assist Vibrator: None  
 Dump Apron: Standard 1/4" Plate - 10"  
 Side Light Cutouts: Lower Front/Rear Clearance  
 Cabshield Cutouts: 1 Set  
 Metro Light Cutouts: 1 set  
 Dirt Shedding Angle: No  
 Board Holder Height: 8"  
 ID: 85"  
 Cover Bottom Rail with Alum: No  
 \*\*Cab Height\*\*To be Verified: Not Available  
 \*\*Paint\*\*To be Verified: Stock Ox Color



# Quote Response Form

**TRUCK BODIES & EQUIPMENT INTERNATIONAL, Inc.**  
 Ox Bodies | Crysteel | DuraClass | Rugby | J-Craft | Hardee

TBEI - Ox Bodies  
 719 Columbus Street East  
 PO Box 886  
 Fayette AL 35555  
 800-844-2519

**End User:** HIDALGO COUNTY DRA  
**Customer:** 104731  
 Mark Brunnemann  
 HOLT TRUCK CENTERS  
 1320 SOUTH 25TH STREET  
 EDINBURG TX 78539  
 USA

**Phone:** 956-289-7636  
**Fax:** 956-383-6819

**Taken By:** Jennifer Reed

Estimate	Terms	Quote Date	Expiration Date	Salesperson	Customer Currency
FA00062186	Net 30 Days	3/11/2015	4/10/2015	HOWARD, CHIP	USD

UM	Quantity	Item	Unit Price	Extended Price
----	----------	------	------------	----------------

Truck: Truck  
 Truck: Installed  
 Side Boards: 1248918-Wood 8" - Up to 17' body  
 Hydraulic Tank: 1250596-Pyramid Flat Bottom Standard  
 Rear Hinge: Standard - Removable Pin  
 Hoist: 1248910-63130  
 Cab Controls: Man. Transmission: 1248922-AS PTO/CS Pmp/Man Trs/EI MT Tarp  
 Pump - Manual Transmission: 1249977-CS/Man/Pump C102-D2.5-3 D/MT CCW  
 PTO - Manual Transmission: 1265632-Manual Transmission, Double Gear  
 Mud Flaps: 1250015- 30" Standard Mud Flaps w/GG  
 Backup Alarm: 1248915-Back-Up Alarm  
 Side Light Quantity: Lower Front Amber / Rear Clearance Red  
 Cab Shield Light Quantity: 1 set Amber  
 Metro Light Quantity: 1 set Red

EA	1.000	1249365	TARP ELEC MT MESH N/FL AL 10-16 IN:	1,116.00	1,116.00
EA	1.000	1250302	HITCH 22" 45TON W/GLADS 7-PIN INST.	1,100.00	1,100.00

\*\*\*\*\***AUTO TRANS - ADD \$1155.00** CX31 only  
 REQUIRED CT: 120"-126"

Requested 01/14/14

<b>Gross Sales:</b>	13,027.00
<b>Total Discounts:</b>	834.89
<b>Sale Amount:</b>	12,192.11
<b>Freight:</b>	1,800.00
<b>Sales Tax:</b>	0.00
<b>FET Charges:</b>	0.00
<b>Total Amount:</b>	13,992.11



**CONTRACT PRICING  
WORKSHEET**  
For Catalog & Price Sheet Type Purchases

Contract No.: **EMO6-15**

Date Prepared: **6/1/2015**

**This Worksheet is prepared by Contractor and given to End User. If a PO is issued, both documents MUST be faxed to H-GAC @ 713-993-4548. Therefore please type or print legibly.**

Buying Agency:	HIDALGO COUNTY DRAINAGE DIST. #1	Contractor:	ANDERSON MACHINERY
Contact Person:	JAIME SALAZAR	Prepared By:	TOM ANDERSON
Phone:		Phone:	(512) 272-8133
Fax:		Fax:	(512) 272-8136
Email:		Email:	TA@AMCOTX.COM

Catalog / Price Sheet Name:	KOBELCO - KCMU MACHINE PRICING
General Description of Product:	SK-260LC-9

**A. Catalog / Price Sheet Items being purchased - Itemize Below - Attach Additional Sheet If Necessary**

Quan	Description	Unit Pr	Total
1	BASE MACHINE	154015	154015
1	SUSPENSION SEAT	STD	STD
1	31.5" SEMI-TRIPLE GROUSER SHOES FOR LC CONFIGURATION	2600	2600
1	60' LONG REACH ATTACHMENT PACKAGE	57762	57762
1	HYDRAULIC PATTERN CHANGER	1264	1264
1	SAFETY MIRROR WITH REAR VIEW CAMERA PACKAGE	STD	STD
1	ROPS/FOPS CAB WITH AC, HEATER, & SOUND SUPPRESSION	STD	STD
1	MACHINE OPERATION MANAGEMENT SYSTEM WITH GPS	STD	STD
1	BELLY PAN PACKAGE	447	447
1	VANDALISM COVERS	2395	2395
1	5YEAR/5000 HOUR FULL MACHINE WARRANTY	7835	7835
<b>Total From Other Sheets, If Any:</b>			
		<b>Subtotal A:</b>	226318

**B. Unpublished Options, Accessory or Service Items - Itemize Below - Attach Additional Sheet If Necessary**  
(Note: Unpublished items are any which were not submitted and priced in contractor's bid.)

Quan	Description	Unit Pr	Total
1	60" CLEAN OUT BUCKET WITH BOLT-ON CUTTING EDGE	STD	STD
			0
			0
			0
<b>Total From Other Sheets, If Any:</b>			
		<b>Subtotal B:</b>	0

<b>Check:</b> Total cost of Unpublished Options (B) cannot exceed 25% of the total of the Base Unit Price plus Published Options (A+B).	<b>For this transaction the percentage is:</b>	<b>0%</b>
---	--	-----------

**C. Trade-In, Special Discounts, Other Allowances, Freight, Installation, Miscellaneous Charges**

		<b>Subtotal C:</b>	0
<b>Delivery Date:</b>	<b>TBA</b>	<b>D. Total Purchase Price (A+B+C):</b>	<b>226318</b>



**Anderson Equipment Company**  
700 West Expressway  
Pharr, TX 78577-0662

Phone: (956)781-5995  
Fax: (956) 781-5999

Hidalgo County Drainage Dist. # 1  
902 Doolittle  
Edinburg, TX 78542  
956-292-7080  
Attn: Jaime Salazar

Jaime,

Along with this letter, I have attached a brochure with specifications for the Kobelco SK260lc Long-reach Excavator. Also included is an HGAC quote for purchase.

The HGAC quote includes requested options listed at the bottom of the page. If any of these are not needed/wanted, please subtract the corresponding amount from the total price.

This unit is currently in our yard in Pharr, TX., ready for immediate delivery.

This particular unit is equipped with a Tier 4i Hino engine. It is Tier 4 'Interim' meaning it does pass EPA regulations but does not come with the higher price of the Tier 4 Final machines. This machine does not require DEF fluid – the Tier 4 Final machines do.

The 5 year/5000 hour warranty quoted, is a Full Machine warranty. Anderson Equipment Co. is an Authorized Kobelco Dealer and we offer full machine Parts and Service support.

Anderson Equipment stocks a full complement of Kobelco parts, filters, etc... locally. If parts are needed we do not have in stock, we can overnight parts from the Kobelco facility in Katy, TX.

Thank you,  
Clay Shotts



700 W. Expwy 83  
Pharr, TX 78577  
[shotts.aeco@gmail.com](mailto:shotts.aeco@gmail.com)  
956-720-1606

• KOBELCO • LIUGONG • BOMAG • GROVE CRANES • NATIONAL CRANES •  
• BRODERSON CRANES • TIGER MOWERS • CEDARAPIDS • GEHL FORKS •



Tom Anderson &lt;ta@amcotx.com&gt;

---

**H-GAC Awards Notice - EM06-15**

1 message

**Levy, Beverly** <Beverly.Levy@h-gac.com>

Mon, Apr 20, 2015 at 4:31 PM

To: "Levy, Beverly" &lt;Beverly.Levy@h-gac.com&gt;

Cc: "Denzel, Brian" &lt;Brian.Denzel@h-gac.com&gt;, "Lundy, Jennifer" &lt;Jennifer.Lundy@h-gac.com&gt;

To: All Respondents of Record

Re: Notification of Contract Award Recommendations

Invitation #: EM06-15

Product/Service: Earth Moving &amp; Construction Equipment

H-GAC Board Date: April 21, 2015

Thank you for your response to our bid invitation. Attached is the contract award recommendations document for which the H-GAC Board of Directors will vote on (4/21). If you have been recommended for a contract award, you should receive contract documents for signature shortly. NOTE: recommended contractors may not process any purchase orders until the signed contract documents have been executed and returned to H-GAC.

To assist and support contractors in the effective use of our program, H-GAC hosts ongoing teleconference "Contractor Orientations". They cover program operations, handling new participants, contract pricing worksheets, marketing, and other related program information. Once contract documents have been signed and returned to H-GAC, contractors should sign up for the earliest convenient orientation session as the dates become available on our calendar. Contractors should include, at a minimum, the staff person(s) who will be the day-to-day contact(s) for our participants wishing to place orders or obtain information. However, any of your staff who will be working with our program are welcome and encouraged to attend. Contractors should use the orientation registration form at the following link:

<http://www.hgacbuy.org/events/>

Once signed up for a session, an H-GAC staff member will supply you with an orientation phone number and log-in instructions

*Beverly Levy*

*Specifications Specialist*

**HGACBuy**

*Cooperative Purchasing*

832-681-2592

*Beverly.Levy@h-gac.com*

 **psc-Earth-Moving-and-Construction-Equipment.pdf**  
128K

## COOPERATIVE PURCHASING PROGRAM EARTH MOVING AND CONSTRUCTION EQUIPMENT

### Background

H-GAC received and opened twenty-five competitive bids for Earth Moving and Construction Equipment on February 12, 2015. The following companies submitted bids:

AL-jon Manufacturing LLC	Ottumwa, IA
Anderson Machinery Austin Inc.*	Manor, TX
Associated Supply Co., Inc (dba ASCO Equipment) *	Lubbock, TX
Bane Machinery, Inc.*	Dallas, TX
Bell Trucks America Inc	Houston, TX
Clark Equipment Company dba Bobcat Company	West Fargo, ND
Clark Equipment Company d/b/a Doosan Infracore Construction Equipment America*	Suwanee, GA
Doggett Heavy Machinery Services, LLC*	Houston, TX
Earth Tool Company, LLC	Lake Mills, WI
EKA	Stone Mountain, GA
GS Equipment, Inc.	Tampa, FL
Humdinger Equipment, LTD.	Lubbock, TX
John Deere Construction Retail Sales, a Division of John Deere Shared Service, Inc.	Moline, IL
Kirby-Smith Machinery, Inc*	Dallas, TX
Kubota Tractor Corporation	Torrance, CA
Landmark Equipment, Inc.	Irving, TX
Land Pride, A Division of Great Plains MFG., INC	Salina, KS
Menzi USA Sales Inc.	Lakeland, FL
Mustang Machinery Company, LTD. dba Mustangs Cat	Houston, TX
One Source Equipment, LP	Throckmorton, TX
RDO Equipment Co.	Fort Worth, TX
ROMCO Equipment Co.	Houston, TX
Takeuchi Mfg. (U.S) Ltd	Pendergrass, GA
Terex Trucks Americas*	Southaven, MS
Volvo Construction Equipment North America, LLC*	Shippensburg, PA

\*Joint Bid

### Current Situation

H-GAC staff have evaluated all bid responses and recommends twenty-four bids (consisting of eighty-five vendors) for award. The response from Land Pride, A Division of Great Plains MFG., Inc was non compliant due to incomplete required forms.

**Funding Source:** Participating local government purchasers

**Budgeted:** N/A

### Action Requested

Request authorization of contracts with lowest priced responsible bidders for product items as summarized in the following Award Recommendation Table and, as may be applicable to extend contract assignments to other authorized entities during the contract period. If an awarded bidder fails to execute a contract within forty-five days, authorization is requested to contract with the next lowest priced responsible bidder.

(over)

EM06-15 Award Recommendation Table

H-GAC Product Code	Bidder
<b>Al-jon</b>	
52A	AL-jon Manufacturing LLC
<b>Allied</b>	
53A	Bane Machinery, Inc.
<b>Allied Construction Products LLC</b>	
54A-54C	Bane Machinery, Inc.
<b>Allu</b>	
55A	Bane Machinery Inc.
<b>Arrow Master</b>	
01A	Associated Supply Co., Inc (dba ASCO Equipment), CLM Equipment Co., Inc., Coleman Equipment Inc., Construction-Agricultural Supply Company Inc., Folcomer Equipment Corporation, Lawrence Equipment Company, Nueces Farm Center, Inc. dba Nueces Power Equipment, OCT Equipment LLC, Permian Tractor Sales Inc, Sonsray Machinery, LLC., Titan Machinery, Inc., The Victor L. Phillips Company, Century Equipment Company, Inc.
<b>Bell</b>	
56A	Bell Trucks America Inc.
56B	Anderson Machinery Austin, Inc.
<b>Bobcat</b>	
05A-05C	Clark Equipment Company dba Bobcat Company
<b>Case</b>	
07A-07L	Associated Supply Co., Inc (dba ASCO Equipment), CLM Equipment Co., Inc., Coleman Equipment Inc., Construction-Agricultural Supply Company Inc., Folcomer Equipment Corporation, Lawrence Equipment Company, Nueces Farm Center, Inc. dba Nueces Power Equipment, OCT Equipment LLC, Permian Tractor Sales Inc, Sonsray Machinery, LLC., Titan Mchinery, Inc., The Victor L. Phillips Company, Century Equipment Company, Inc.
<b>Caterpillar</b>	
08A-08T	Mustang Machinery Company, LTD. dba Mustangs Cat
<b>Diamond Z</b>	
57A	Bane Machinery, Inc.
<b>Ditch Witch</b>	
10A-10C, 10E-10G, 10I, 10K,10M	EKA

<b>Doosan</b>	
11A-11C	Clark Equipment Company d/b/a Doosan Infracore Construction Equipment America, R.B. Everett & Company, Venture Drilling Supply, H & V Equipment Services, Inc.
<b>Dressta</b>	
12A	Anderson Machinery Austin Inc.
<b>Gehl</b>	
14A-14D	Kirby-Smith Machinery, Inc, Waukesha-Pearce Industries Inc., Linder Industrial Machinery, Anderson Machinery Austin, Inc.
<b>Genesis</b>	
60A	Bane Machinery, Inc.
<b>Gradall</b>	
15A-15C	Kirby-Smith Machinery, Inc, Waukesha-Pearce Industries Inc., Linder Industrial Machinery, Gradall Industries, Inc., Associated Supply Company, Inc. d/b/aASCO Equipment Co.
<b>Grove</b>	
16A-16D	Anderson Machinery Austin, Inc.
<b>Hammerhead</b>	
17A	EKA
17B-17F	Earth Tool Company LLC
<b>Hitachi</b>	
19A-19C	ROMCO Equipment Co.
<b>Humdinger Equipment, LTD</b>	
61A	Humdinger Equipment, LTD.
<b>John Deere</b>	
23A-23R	Doggett Heavy Machinery Services, 4 Rivers Equipment LLC, Beard Equipment, CL Boyd company, Inc., CESCO, Coastal Equipment Corp, Bragg Investment Co., Inc. dba Coastline Equipment, Doggett Machinery Services, Jesco Inc., Murphy Tractor & Equipment Co., Inc., Nortrax Inc., Pape Machinery, RDO Equipment Company, Rowand Machinery Company, Warrior Tractor & Equipment Company, Inc., Yellowhouse Machinery Co.
<b>John Deere Construction</b>	
22A-22D	John Deere Construction Retail Sales a Division of John Deere Shared Service Inc.
<b>Kaiser</b>	
51A	GS Equipment, Inc.
<b>Kawasaki</b>	
24A	Bane Machinery, Inc. C L M Equipment Co., Inc., Abilene New Holland
<b>Kent</b>	

(over)

64A-64C	ROMCO Equipment Co.
<b>Kobelco</b>	
25A	Bane Machinery, Inc., C L M Equipment Co., Inc., Anderson Machinery Austin, Inc.
25B	Anderson Machinery Austin Inc.
<b>Komatsu</b>	
26A-26E	Kirby-Smith Machinery, Inc, Waukesha-Pearce Industries Inc., Linder Industrial Machinery
<b>Kubota</b>	
28A-28C	Kubota Tractor Corporation
<b>LB Performance/ Blaw Knox</b>	
29A	ROMCO Equipment Co.
<b>LBX</b>	
30A	Bane Machinery, Inc, C L M Equipment Co., Inc.,
<b>LeeBoy</b>	
31A	Associated Supply Co., Inc (dba ASCO Equipment), CLM Equipment Co., Inc., Coleman Equipment Inc., Construction-Agricultural Supply Company Inc., Folcomer Equipment Corporation, Lawrence Equipment Company, Nueces Farm Center, Inc. dba Nueces Power Equipment, OCT Equipment LLC, Permian Tractor Sales Inc, Sonsray Machinery, LLC., Titan Machinery, Inc., The Victor L. Phillips Company, Century Equipment Company, Inc.
<b>Luigong</b>	
32A, 32C	Anderson Machinery Austin Inc.
<b>Menzi USA</b>	
36A	Menzi USA Sales Inc.
<b>Midland</b>	
65A	Bane Machinery, Inc.
<b>National</b>	
38A	Anderson Machinery Austin,
<b>New Holland</b>	
39A, 39C-39H	Landmark Equipment, Inc
<b>Nor Am</b>	
40A	Anderson Machinery Austin, Bane Machinery, Inc.
<b>Okada</b>	
68A	RDO Equipment Co.
<b>Paladin Attachments</b>	
69A-69C	EKA
<b>Rosco</b>	
70A	Associated Supply Co., Inc (dba ASCO Equipment), CLM Equipment Co., Inc., Coleman Equipment Inc., Construction-Agricultural Supply Company Inc., Folcomer Equipment Corporation,

	Lawrence Equipment Company, Nueces Farm Center, Inc. dba Nueces Power Equipment, OCT Equipment LLC, Permian Tractor Sales Inc, Sonsray Machinery, LLC., Titan Mchinery, Inc., The Victor L. Phillips Company, Century Equipment Company, Inc.
<b>Sany</b>	
42A-42B	Landmark Equipment, Inc
<b>Sennebogen</b>	
72A	Bane Machinery, Inc.
<b>Takeuchi</b>	
43A-43D	Takeuchi Mfg. (U.S) Ltd
<b>Tana</b>	
67A-67B	Humdinger Equipment, LTD.
<b>Terex</b>	
45A-45E, 45H-45I	One Source Equipment, LP
<b>Terex Trucks Americas</b>	
74A	Terex Trucks Americas, Bane Machinery, Inc.
<b>Volvo</b>	
49A-49J	Volvo Construction Equipment North America, LLC, Alta Equipment LLC, Aring Equipment Company, Arnold Machinery Company, ASC Construction Equipment, Associated Supply Inc, Chadwick-BaRoss Inc., Clyde/West Inc, Construction Machinery Industrial, LLC, Cowin Equipment Compnay Inc, Flagler Construction Equipment Company, LLC., The G. W. Van Keppel Co., Golden Equipment Company, Hugg & Hall Equipment Company, Highway Equipment & Supply Co, Malvese Equipment Co. Inc., McAllister Equipment Co., McClung-Logan Equipment Co., Inc., PennJersey Machinery, LLC, Power Equipment Company, ROMCO Equipment Co., Rudd Equipment Company, Scott Equipment Company, L.L.C., Sheehan Mack Sales & Equipment, Sierra Machinery Inc., Swanston Equipment Corporation, Tri-State Truck & Equipment Inc, Tyler Equipment Corp., Vantage Equipment, LLC, SABA Holding Company, LLC., Woodco Machinery Inc.
<b>Woodsman</b>	
75A	Bane Machinery, Inc.





Administration

RFQ

Purchase Order

Reports

Shopping Cart

Help

## Vendor Contract Information

[Back](#)

Search:

- All  
 Vendor Discounts Only  
 Catalog Pricing Only

### Refine Your Search:

#### Vendors

Silsbee Ford[X]

#### Price Range

Show all prices

#### Category

None Selected

#### Contract

None selected

### Additional Searches:

[Search by Vendor](#)
[Browse Contracts](#)
[Instructional Materials](#)
**Vendor Name:** Silsbee Ford**Address:** 1211 US HWY 96 N

Silsbee, TX 77656

**Phone Number:** (409) 895-3800**Email:** rhyder.cowboyfleet@gmail.com**Federal ID:** 76-0533144**Contact:** Richard Hyder**Accepts RFQs:** Yes**Minority Owned Vendor:** No**Women Owned Vendor:** No**Contract Name:** Vehicles, Heavy Duty Trucks & Options**Contract#:** 430-13**Effective Date:** 12/01/2013**Expiration Date:** 11/30/2016**Service Fee:** Purchase order subject to a \$400 service fee**Payment Terms:** Net 30 days**Delivery Days:** 90**Shipping Terms:** Pre-paid and added to invoice**Freight Terms:** FOB Destination**Ship Via:** Common Carrier**Region Served:** All Texas Regions**States Served:** All States

**Additional Info:** NOTE: As per the specifications for BuyBoard Proposal No. 430-13, and except for delivery fees as explained below, all vehicle fees (i.e. pre-deliver inspection, make ready, State of Texas inspection, manufacturer destination fees, etc.) charged for any purchase from this contract are included in the awarded vehicle base price(s). Vehicle fees not included in the base price(s) are not allowed and should not appear on the awarded dealer's quote for a vehicle offered for purchase under the contract. The Cooperative service fee is not a "vehicle fee" and is not included in the base pricing. Only those vendors whose awarded pricing is stated on the BuyBoard on a per mile basis may charge a vehicle delivery fee. The above information has been communicated to Cooperative members.

**Quote Reference Number:** 430-13**Return Policy:** 25% restocking fee during first 30 days.

### Contract Documents

**Proposal Documents:** [Click to view BuyBoard Proposal Documents](#)
**Regulatory Notice:** [Click to view Bonding Regulatory Notice](#)

Contact us 800-695-2919



Sisbee Ford, Inc.  
 1211 U.S. 96 North, Sisbee, Texas, 77656  
 Office: 409-385-3724

**2016 Fusion**  
 4dr FWD Sedan S(P00G)

**Major Equipment**

(Based on selected options, shown at right)

Duratec 2.5L I-4 DOHC w/SMPI 175hp 6 speed automatic w/OD	Exterior: Oxford White Interior: Earth Gray
* 4-wheel ABS	* Brake assistance
* Electric parking brake	* Traction control
* P 215/60R16 BSW AS H-rated tires	* Battery with run down protection
* Advance Trac w/Roll Stability Control	* Air conditioning
* Tinted glass	* AM/FM stereo with seek-scan, single in-dash CD player, MP3 decoder, auxiliary audio input, external memory control, internet radio
* Bluetooth wireless streaming	* Daytime running
* LED brakelights	* Rear child safety locks
* Dual power remote mirrors	* Variable intermittent speed-sensitive wipers
* 16 x 6.5 aluminum wheels	* Dual front airbags
* Driver and front passenger seat mounted side airbags	* Airbag occupancy sensor
* Securilock immobilizer	* Rear window defroster
* Tachometer	* Message Center
* Underseat ducts	* Reclining front bucket seats
* 60-40 folding rear bench	* Audio control on steering wheel

**Fuel Economy**

**City**  
N/A



**Hwy**  
N/A

**Selected Options**

STANDARD VEHICLE PRICE	\$22,600.00	MSRP
Equipment Group 100A	(\$490.00)	
Engine: 2.5L IVC T		N/A
Transmission: 6 Speed Automatic w/SelectShift		N/A
Tires: P215/60R16 BSW All Season		N/A
Wheels: 16" Alloy		N/A
Cloth Front Bucket Seats	Included	
Monotone Paint Application		N/A
Radio: AM/FM Stereo/MP3/Single-CD		N/A
SYNC Communications & Entertainment System		N/A
Oxford White		N/C
Earth Gray		N/C

**Uppfit Options**

SUBTOTAL	\$22,110.00
Destination Charge	\$825.00
<b>TOTAL</b>	<b>\$22,935.00</b>

Prices and content availability as shown are subject to change and should be treated as estimates only. Actual base vehicle, package and option pricing may vary from this estimate because of special local pricing, availability or pricing adjustments not reflected in the dealer's computer system. See salesperson for the most current information.

Prepared By: Richard Hyder Date: 05/20/2015 | Price Level: 615



WDS - The Valley  
 1209 E Jasmine Avenue  
 Suite B  
 McAllen, TX 78501  
 Phone No.: 956-961-4591  
 Fax No.: 956-961-4594  
 Home Page: www.wds-us.com

SALES QUOTE

Sales Quote Number: SQ-20940  
 Sales Quote Date: 05/21/15  
 Page: 1  
**Quote Expiration Date: 06/20/15**



Sell  
 To: Hidalgo County Planning Dept.  
 1304 South 25th Street  
 Edinburg, TX 78539

Ship  
 To: Hidalgo County Planning Dept.  
 1304 South 25th Street  
 Edinburg, TX 78539

Customer ID 426100

Ship Via

Terms Net 30 Days

SalesPerson Pratt Vivekanandan

**R10 COMPLETE VRS ROVER**

Item No.	Description	Unit	Quantity	Unit Price	DIR		Total Price
					Disc. %		
R10-001-60	R10 with internal 410-470 MHz Radio	Each	1	25,500.00	18		20,910.00
TSC3-01-1012	TSC3, Access, No Radio, ABCD Supports CDMA and GSM	Each	1	5,495.00	18		4,505.90
43169-00	Rod - 2.0m Carbon Fiber Range Pole with Bipod	Each	1	519.75	18		426.19
82768-00	TSC3 GNSS Accessory Kit	Each	1	320.00	18		262.40
VRSMEM	TX/OK COOP NETWORK MEMBERSHIP	Each	1	2,000.00			2,000.00
DIRSHIP	Shipping Included	Each	1				

- Earning Your Business is our Top Priority
- 6 Local Offices to Serve Your Needs
- WDS Dedicated Support Line Included
- WDS Warranty Repair Loaners Included
- Serving the Geospatial Community for Over 30 Years

Subtotal: 28,104.49  
 Invoice Discount: 0.00  
 Total Sales Tax: 0.00  
 Total: 28,104.49



## North American Western Data Systems, Inc dba Western Data Systems

**Vendor ID**

17600888030

**URL**
Vendor Website
<http://www.westerndatasystems.com/dir.html>
**HUB Type**

Non HUB

**DIR Contract Number**

DIR-SDD-1796

**Contract Term End Date**

3/13/2016

**Contract Exp Date**

3/13/2016

**Contact North American Western Data Systems, Inc dba Western Data Systems**
**Contact**
Robb Delprado
<mailto:robb@westerndatasystems.com>
**Phone**

(281) 987-1815

**Fax**

(281) 987-2743

**Contact DIR**
**Contact**
Stephanie Harrison
<mailto:stephanie.harrison@dir.texas.gov>
**Phone**

(512) 463-3290

**Fax**

(512) 475-4759

### Contract Overview

North American Western Data Systems offers IT based land surveying products and services through this contract, including: maintenance/repair and training. Available brands include: Trimble. Customers can purchase directly through this DIR contract. Contracts may be used by state and local government, public education, other public entities in Texas, as well as public entities outside the state. Resellers are not available for this contract.

### Contract Documents

- [Contract DIR-SDD-1796 PDF \(188.68KB\)](#)  
<http://publishingext.dir.texas.gov/portal/internal/contracts-and-services/Contracts/Contract DIR-SDD-1796.pdf>
- [DIR-SDD-1796 Appendix A Standard Terms and Conditions PDF \(701.94KB\)](#)  
<http://publishingext.dir.texas.gov/portal/internal/contracts-and-services/Contracts/DIR-SDD-1796 Appendix A Standard Terms and Conditions.pdf>
- [DIR-SDD-1796 Appendix B HUB Subcontracting Plan PDF \(516.39KB\)](#)

<http://publishingext.dir.texas.gov/portal/internal/contracts-and-services/Contracts/DIR-SDD-1796 Appendix B HUB Subcontracting Plan.pdf>

- [DIR-SDD-1796 Appendix C Pricing Index PDF \(83.83KB\)](http://publishingext.dir.texas.gov/portal/internal/contracts-and-services/Contracts/DIR-SDD-1796 Appendix C Pricing Index.pdf)
- [DIR-SDD-1796 Appendix D Master Operating Lease Agreement PDF \(236.37KB\)](http://publishingext.dir.texas.gov/portal/internal/contracts-and-services/Contracts/DIR-SDD-1796 Appendix D Master Operating Lease Agreement.pdf)
- [DIR-SDD-1796 Appendix E Master Lease Agreement PDF \(299.63KB\)](http://publishingext.dir.texas.gov/portal/internal/contracts-and-services/Contracts/DIR-SDD-1796 Appendix E Master Lease Agreement.pdf)
- [DIR-SDD-1796 Amendment 1 PDF \(53.03KB\)](http://publishingext.dir.texas.gov/portal/internal/contracts-and-services/Contracts/DIR-SDD-1796 Amendment 1.pdf)
- [DIR-SDD-1796 Amendment 2 PDF \(135.34KB\)](http://publishingext.dir.texas.gov/portal/internal/contracts-and-services/Contracts/DIR-SDD-1796 Amendment 2.pdf)
- [DIR-SDD-1796 Amendment 3 PDF \(143.44KB\)](http://publishingext.dir.texas.gov/portal/internal/contracts-and-services/Contracts/DIR-SDD-1796 Amendment 3.pdf)

## Electronic and Information Resources (EIR) Accessibility

Information regarding Electronic and Information Resources (EIR) accessibility of this vendor's offerings is included in the contract. Agencies purchasing products or services are responsible for complying with Texas EIR Accessibility statute and rules, as defined in TGC 2054 Subchapter M, 1TAC 206, and 1 TAC 213. For additional information, visit the Vendor Website or contact the vendor directly.

Please note that some of the documents on this page are in the PDF format. Please [download the Adobe Reader](http://get.adobe.com/reader/) in order to view these documents.

---

## How To Order

1. For product and pricing information, visit the [North American Western Data Systems, Inc dba Western Data Systems](http://www.westerndatasystems.com/dir.html) website or contact [Robb Delprado](mailto:robb@westerndatasystems.com) at (281) 987-1815
2. Generate a purchase order made payable to North American Western Data Systems, Inc dba Western

Show more

**Available Brands (1 total)**

Trimble

Show more

**Available Products & Services (1 total)**

IT Based Land Surveying

Show more

**Commodity Codes (5 total)**

208-85 - Surveying Systems Software

209-86 - Surveying Systems Software

305-21 - Direct Print Supplies, Dry Process

305-80 - Surveying Systems, Geo/Satellite Navigation Type

Show more

---

**© 2015 Department of Information Resources**

300 W. 15th Street, Suite 1300

Austin, TX 78701 | 512.475.4700

**Appendix C to DIR Contract No. DIR-SDD-1796  
Pricing Index**

Product Description	Customer Discount
<b>Trimble</b>	
Survey Products	12.50%
GIS/Mapping Products	12.50%
Building Construction Tools	14.50%
Trimble Compatible Peripheral Items: Including USR Ground Penetrating Radar, Schonstedt Pipe Locators and Ricoh Digital Cameras	9.50%
<b>Services</b>	
Maintenance and Repair	9.50%
Training	9.50%
Extended Hardware Warranties	12.50%
Extended Firmware Warranties	12.50%

**HIDALGO COUNTY DRAINAGE DISTRICT NO. 1**  
**GASOLINE, ON & OFF HIGHWAY DIESEL FUEL**  
**BID NO.: HCDD1-15-008-05-13**  
**BID TABULATION SHEET - USING 05/06/2015 OPIS REPORT**

APPROXIMATE QUANTITIES	OIL PATCH FUEL & SUPPLY INC.	GOLD STAR PETROLEUM INC.	PRICE DIFFERENCE
<b>UNLEADED PLUS GASOLINE</b>	UNIT PRICE	UNIT PRICE	UNIT PRICE
OPIS PRICE	2.049	2.0462	
STATE TAX	00.20	0.2000	
MARGIN OF PROFIT	00.013	-0.0101	
<b>TOTAL PRICE PER GALLON</b>	<b>2.262</b>	<b>2.2361</b>	<b>0.0259</b>

<b>SUPER UNLEADED GASOLINE</b>	UNIT PRICE	UNIT PRICE	UNIT PRICE
OPIS PRICE	2.3050	2.3077	
STATE TAX	00.20	0.2000	
MARGIN OF PROFIT	00.013	-0.0101	
<b>TOTAL PRICE PER GALLON</b>	<b>2.518</b>	<b>2.4976</b>	<b>0.0204</b>

<b>UNLEADED GASOLINE</b>	UNIT PRICE	UNIT PRICE	UNIT PRICE
OPIS PRICE	1.9250	1.9462	
STATE TAX	00.20	0.2000	
MARGIN OF PROFIT	00.013	-0.0101	
<b>TOTAL PRICE PER GALLON</b>	<b>2.138</b>	<b>2.1361</b>	<b>0.0019</b>

**HIDALGO COUNTY DRAINAGE DISTRICT NO.1**  
**GASOLINE, ON & OFF HIGHWAY DIESEL FUEL**  
**BID No.: HCDD1-15-008-05-13**  
**PRICE COMPARISON SHEET - 05/06/2015 OPIS REPORT**

APPROXIMATE QUANTITIES	OIL PATCH FUEL & SUPPLY INC.	GOLD STAR PETROLEUM, INC.	PRICE INCREASE
<b>OFF HIGHWAY DIESEL FUEL</b>	UNIT PRICE	UNIT PRICE	UNIT PRICE
Opis Price	2.0540	2.0711	
State Tax	00.20	.00	
Margin of Profit	00.013	-0.0101	
<b>Total Price Per Gallon</b>	<b>2.267</b>	<b>2.0610</b>	<b>0.206</b>

<b>ON HIGHWAY DIESEL FUEL</b>	UNIT PRICE	UNIT PRICE	UNIT PRICE
Opis Price	2.0503	2.0807	
State Tax	00.20	0.2000	
Margin of Profit	00.013	-0.0101	
<b>Total Price Per Gallon</b>	<b>2.2632</b>	<b>2.2706</b>	<b>0.0074</b>

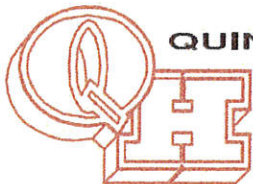

**QUINTANILLA, HEADLEY AND ASSOCIATES, INC.**

**Consulting Engineers ★ Land Surveyors**

Alfonso Quintanilla, P.E. # 95534 R.P.L.S #4856 Eulalio Ramirez, P.E. # 77062  
Engineering Firm Registration No. F-1513  
Surveying Firm Registration No. 100411-00  
Municipal & County Projects ★ Subdivisions ★ Surveys

May 18, 2015

Honorable Commissioner A.C. Cuellar, Jr.  
Hidalgo County Precinct No. 1  
1902 Joe Stephens Ave., Suite 101  
Weslaco, Texas 78599

Re: RFB No.: HCDD1-15-006-04-29A "Pct. 1 – Tijerina Rural Development Drainage Improvements Project" and GLO Contract No. 12-406-000-6453/DRS210068.

Dear Mr. Cuellar:

Bids for the above mentioned project were received and opened for RFB No.: HCDD1-15-006-04-29A "Pct. 1 – Tijerina Rural Development Drainage Improvements Project" and GLO Contract No. 12-406-000-6453/DRS210068 on Wednesday May 13, 2015. Ten (10) Bids were received with ICE (International Consulting Engineers) being the low bidder with the selected alternate for the project. Attached is a copy of the bid tabulation for your review.

This project consists of the construction of a new storm grading system with proposed inlets, manholes, roadside ditch, traffic control and 18", 24", and 30" storm drain pipe. Ice is a new company with staff that has worked on projects satisfactorily within Hidalgo County. We recommend awarding the project to Ice for the Base Bid and replacing the concrete storm sewer pipe in the Base Bid with Alternate No0. 2 for a total amount of \$240,152.00.

If you have any questions or require additional information, please feel free to contact us at (956) 381-6480.

Respectfully,

---

Eulalio Ramirez, P.E.  
Project Engineer

Attachments: Bid Comparison

Pct 1 Tijerina Project

	Base Bid & Alt No.1	Bid w/ Alt No.2	Bid w/ Alt No.3
Jimmy Closner	\$366,150.00	\$142,990.00	\$142,990.00
	\$76,078.00	\$284,718.00	\$287,318.00
<b>Total:</b>	<b>\$442,228.00</b>	<b>\$427,708.00</b>	<b>\$430,308.00</b>
Saenz Brothers	\$306,890.00	\$148,210.00	\$148,210.00
	\$130,472.00	\$307,760.00	\$305,040.00
<b>Total:</b>	<b>\$437,362.00</b>	<b>\$455,970.00</b>	<b>\$453,250.00</b>
Pega JPS	\$216,090.00	\$81,090.00	\$81,090.00
	\$52,576.00	\$171,968.00	\$195,764.00
<b>(1) Total:</b>	<b>\$268,666.00</b>	<b>(2) \$ 253,058.00</b>	<b>(2) \$276,854.00</b>
Ice Int.	\$225,860.00	\$101,340.00	\$101,340.00
	\$47,072.00	\$138,812.00	\$173,732.00
<b>(2) Total:</b>	<b>\$272,932.00</b>	<b>(1) \$240,152.00</b>	<b>(1) \$275,072.00</b>
DK3	\$251,735.00	\$95,218.90	\$95,218.90
	\$119,705.80	\$234,848.40	\$232,176.95
<b>Total:</b>	<b>\$371,440.80</b>	<b>\$330,067.30</b>	<b>\$327,395.85</b>
Diamond	\$351,541.70	\$222,607.30	\$222,607.30
	\$41,730.88	\$141,315.28	\$129,067.68
<b>Total:</b>	<b>\$393,272.58</b>	<b>\$363,922.58</b>	<b>\$351,674.98</b>
GO Underground	\$280,182.80	\$129,510.00	\$129,510.00
	\$56,837.56	\$186,153.80	\$201,169.80
<b>Total:</b>	<b>\$337,020.36</b>	<b>\$315,663.80</b>	<b>\$330,679.80</b>
The 5125	\$233,333.33	\$115,093.33	\$115,093.33
	\$67,777.70	\$166,666.66	\$239,140.00
<b>(3) Total:</b>	<b>\$301,111.03</b>	<b>(3) \$281,759.99</b>	<b>\$354,233.33</b>
V.G. Vanguard Engineering	\$251,520.00	\$118,520.00	\$118,520.00
	\$65,896.00	\$165,596.00	\$162,720.00
<b>Total:</b>	<b>\$317,416.00</b>	<b>\$284,116.00</b>	<b>(3) \$281,240.00</b>
RDH	\$278,820.00	\$100,180.00	\$100,180.00
	\$65,500.00	\$216,924.00	\$238,580.00
<b>Total:</b>	<b>\$344,320.00</b>	<b>\$317,104.00</b>	<b>\$338,760.00</b>

## EXHIBIT "E"

PROFESSIONAL ENGINEERING SERVICES CONTRACT DATED FEBRUARY 5, 2013, FOR THE LA JOYA WATERSHED IMPROVEMENT PROJECT FOR HIDALGO COUNTY PRECINCT 3 (THE "AGREEMENT")  
WORK AUTHORIZATION FORM

### WORK AUTHORIZATION NO. 7

THIS WORK AUTHORIZATION is made pursuant to the terms and conditions of Section I.A. of the Agreement made by and between Hidalgo County Drainage District No. 1 hereinafter called the "Owner", and L&G Engineering, professional Engineers hereinafter called "Engineer".

#### PART 1. SCOPE OF WORK

The purpose of this Work Authorization is to provide an updated H&H analysis for the La Joya Watershed Master Drainage Plan (MDP) and the US 83 Relief Route Hydraulic Study to provide requested flows for the modified outfall structure into the Rio Grande River, as part of the La Joya Watershed Improvement project.

*The scope of work for said services is better defined in the following and attached hereto:*

*EXHIBIT "A" – Services to be provided by the Owner*

*EXHIBIT "B" – Services to be provided by the Engineer*

#### PART 2. ESTIMATED COST

The estimated cost for services under this Work Authorization is \$19,738.40. This amount is based upon the costs outlined in the Estimated Cost Proposal attached hereto as *EXHIBIT "D-1" – Estimated Project Fee Schedule*.

#### PART 3. PAYMENT

Compensation and payment to the Engineer for the services established under this Work Authorization shall be made in accordance with Article/Part/Section 6 of the Agreement.

#### PART 4. FUNDING

This Work Authorization No. 7 shall be funded through funding source:

Account No. \_\_\_\_\_

Requisition Number \_\_\_\_\_

#### PART 5. PERIOD OF SERVICE

This Work Authorization shall become effective on the date of final acceptance of the parties hereto, and terminate upon completion of the scopes of this work authorization.

#### PART 6. RESPONSIBILITIES AND OBLIGATIONS

**PART 6. RESPONSIBILITIES AND OBLIGATIONS**

This Authorization does not waive the parties' responsibilities and obligations provided under the Agreement.

**PART 7. ACKNOWLEDGEMENT AND CONFIRMATION**

Acknowledgement and confirmation by Mr. Jaime Salazar of HCDD#1 as to content and detail of this Work Authorization No. 7.

BY: \_\_\_\_\_

**PART 8. ACCEPTANCE AND APPROVAL**

This Work Authorization is hereby accepted, approved by the Hidalgo County Drainage District No. 1 and L&G Engineering as indicated below and effective as of \_\_\_\_ day of \_\_\_\_\_, 2015.

**THE ENGINEER:**

**THE OWNER:**

  
\_\_\_\_\_  
Mr. Jacinto Garza, P.E.  
President - L&G Engineering

\_\_\_\_\_  
Chairman of the Board  
Hidalgo County Drainage District No. 1

**APPROVED AS TO FORM:  
ATLAS, HALL, & RODRIGUEZ, LLP**

- \_\_\_\_\_  
Exhibits:  
Location Map  
Exhibit "A" - Services to be provided by the Owner  
Exhibit "B" - Services to be provided by the Engineer  
Exhibit "C" - Work Schedule  
Exhibit "D-1" - Estimated Project Fee Schedule and Man-hour Breakdown  
Exhibit "D-2" - Hydrologist (CSE) Fee Schedule

## EXHIBIT "A"

### Services to be Provided by the Owner

The following provides an outline of the services to be provided by the **Owner** in the development of the La Joya Watershed Improvement Project in Hidalgo County, TX, hereinafter denoted as the **Project**.

The **Owner** will provide to the **Engineer** the following:

- (1) Authorization to the **Engineer** to begin work in accordance with Section 3 of the Agreement.
- (2) Payment for work performed by the **Engineer**, and accepted by the **Owner** in accordance with Section 6 of the Agreement.
- (3) Assistance to the **Engineer**, as necessary, to obtain the required data and information from other local, regional, State and Federal agencies that the **Engineer** cannot easily obtain.
- (4) Provide any available relevant data the **Owner** may have on file concerning the **Project**.
- (5) Provide timely review and decisions in response to the **Engineer**'s request for information and/or required submittals and deliverables, in order for the **Engineer** to maintain the agreed-upon work schedule.
- (6) Attend and participate in progress meetings as required and as coordinated and conducted by the **Engineer**.
- (7) Review and approve change orders as required and prepared by the **Engineer**.

EXHIBIT B  
SCOPE OF SERVICES TO BE PROVIDED BY THE ENGINEER



2299 Lone Star Drive  
Suite 239  
Sugar Land, TX 77479  
(713) 782-3811

May 23, 2015

Damien Tijerina, P.E.  
L&G Engineering Inc.  
900 S. Stewart Road, Suite 5  
Mission, Texas 78572

RE: La Joya Watershed Master Drainage Plan & US 83 Relief Route Outfall

Dear Mr. Tijerina,

Per your request, **Civil Systems Engineering Inc. (CSE)** has prepared this scope of services for the above referenced project. The purpose of this study is to assist L&G, HCDD1, and TxDOT to update the current analyses for the La Joya Watershed Master Drainage Plan (MDP) and the US 83 Relief Route Hydraulic Study to provide requested flows for the modified outfall structure into the Rio Grande River. The request includes providing the updated proposed TxDOT condition multiple frequency flows and the La Joya Watershed Ultimate Condition multiple frequency flows for the proposed outfall. The proposed outfall has been modified and re-routed from the previous proposed system outfall into the Edinburg Canal. The new proposed outfall is to consist of an interim sized pipe from downstream of the proposed detention basins, located south of US 83, to an existing box at W. Military Road which outfalls through the Rio Grande River levee into an existing river inlet. As part of this proposed TxDOT outfall system, ultimate condition crossings are also to be constructed at the Edinburg Canal and railroad. The ultimate condition is based on the full-development condition for the entire La Joya Watershed. The specific proposed outfall modifications include the following:

- 1) Eliminating the existing 30" outfall to the Edinburg Drain as a drainage outfall for the La Joya Watershed and US 83 Relief Route systems.
- 2) Proposed an outfall pipe (interim) to service the TxDOT US 83 Relief Route project. The outfall will run south from the existing TxDOT ditch to an outfall box structure under W. Military Road, which runs through the river levee.
- 3) Proposing the ultimate condition structures along the new proposed TxDOT outfall alignment under the Edinburg Drain and railroad.
- 4) Eliminating the proposed TxDOT channel improvements from approximately 700 feet south of US 83 downstream (south) to the existing TxDOT channel and proposed TxDOT outfall pipe.
- 5) Utilizing the Hidalgo County proposed 72-acre detention basins as facilities to provide conveyance, in addition to storage, to the existing TxDOT ditch and proposed TxDOT outfall pipe.

In order to size the ultimate condition outfall systems, the following task items are required:

- 1) Coordinating with L&G the design and configuration of channel section, detention basins, interconnections, and culverts south of US 83.
- 2) Updates to the US 83 RR HEC-HMS Model including:
  - a. Modifying the channel & basin routing and outfall configurations south of US 83.
- 3) Updates to the La Joya Watershed MDP Ultimate Condition HEC-HMS Model (2014) including:
  - a. Incorporating the new routing (channel & basin) and outfall configurations south of US 83.
  - b. Addition of drainage areas south of the current 30" outfall location.

- c. Interconnections between the North, Mid-Reach, and South Watersheds to represent the ultimate development & drainage infrastructure condition
  - i. La Joya 2014 report presented an interim watershed condition without interconnections due to utilization of existing 30" outfall to Edinburg Drain.
- 4) Additional modeling modifications that are anticipated including:
  - a. Sizing of the proposed TxDOT outfall structure from the existing TxDOT ditch south of US 83 to the existing outfall box at W. Military Road for multiple frequencies.
  - b. Sizing of the crossing structures under canal and railroad along the proposed TxDOT outfall pipe alignment based on the La Joya Watershed Master Drainage Plan ultimate condition flows.
  - c. Updating the US83RR HEC-RAS model to match modified design plans
  - d. Sizing of the 72-acre detention basin interconnection culvert (located between basin cells) and the basin outfall culvert into the existing TxDOT ditch upstream of the proposed TxDOT outfall pipe.
- 5) Technical memorandum to document plan design and modeling changes and results.

A total amount of **\$17,500.00** for the proposed scope of work is estimated (see Estimated Manhours and Costs by Tasks).

Please let me know if you have any questions regarding this proposed scope of services.

Sincerely,



Deren Li, Ph.D., P.E., D.WRE, CFM  
President



**EXHIBIT C - WORK SCHEDULE - LaJoya Watershed Updates**

	Descriptions	Week1 15-May	Week 2 22-May	Week3 29-May	Week4 5-Jun
1	Coordination of design and channel/basin configuration				
2	Updates to the US83 RR HEC-HMS Model				
3	Updates to the LaJoya MDP HEC-HMS Model				
4a	Sizing of TxDOT New Outfall Structure				
4b	Sizing of Ultimate Condition Structure Crossings				
4c	Updating the US83RR HEC-RAS Model				
4d	Sizing of Detention Basin Culverts and Outfalls				
5	Technical Memorandum				

**EXHIBIT D-1**  
**ESTIMATED PROJECT FEE SCHEDULE AND MAN-HOUR BREAKDOWN**  
**LA JOYA WATERSHED IMPROVEMENT PROJECT**  
**Work Authorization #7**

	MANHOURS											TOTAL LINE ITEM COST			
	Senior Project Manager	Senior Engineer	Senior Environmental Scientist / Specialist	Project Engineer	Design Engineer	ROW Administrator	EIT	Environmental Scientist / Specialist	Senior Engineer Tech	Engineer Tech	CDD Operator / GIS Analyst		Admin / Clerical	Biologist	TOTAL HOURS
<b>WORK AUTHORIZATION NO. 7</b>	272.59	175.97	134.43	127.92	112.55	106.29	87.28	78.16	78.16	75.03	65.65	56.27	50.02		
<b>FC 161 - Drainage</b>															
1 Contractor and Support of Hydrologist for HEC-HMS Modeling Modifications	4	6										6		15	\$ 2,238.40
1a SUB-CSE - US 63RR HEC-HMS Model, La Joya MDP HEC-HMS Model, Addl Modeling Modifications															\$ 17,500.00
<b>Total</b>	<b>4</b>	<b>6</b>										<b>6</b>		<b>15</b>	<b>\$ 17,500.00</b>
Subtotal Manhour Fee with CSE Costs:														<b>\$ 19,738.40</b>	
<b>Total Project Fee:</b>														<b>\$ 19,738.40</b>	

**AI -49949**

7.

**DRAINAGE DISTRICT**

Meeting Date: 06/02/2015

Submitted By: Claudette Guerrero,  
DRAINAGE DISTRICT

Department: DRAINAGE DISTRICT

---

Information

CAPTION

Discussion and approval of District's Construction Payment Guide and related Exhibits to become part of District's procedural forms when processing construction payments.

BACKGROUND

---

Fiscal Impact

Attachments

guide

---

**Form Review**

<b>Inbox</b>	<b>Reviewed By</b>	<b>Date</b>
Budget & Management	Veronica Ortiz	05/29/2015 03:52 PM
Final Approval	Monica Badillo	05/29/2015 04:47 PM
Form Started By: Claudette Guerrero		Started On: 05/29/2015 03:09 PM
Final Approval Date: 05/29/2015		

# HIDALGO COUNTY DRAINAGE DISTRICT NO. 1

902 N. Doolittle Road Edinburg, TX 78542 (956)292-7080 Fax: (956)292-7084



## Construction Payment Guide

In order to expedite and prevent delays when processing construction payments, the District created a guide to help contractors understand the payment process and provide a clear picture of the contractor's responsibilities throughout the project's construction phases.

Every project has unique circumstances. Forms not covered in this guide will be addressed based on the General Conditions of the contract on a "as-needed basis". Please ensure support documentation is included based on applicable phase.

### Pre-Construction:

To expedite the project's set up with Financial Accounting, the Project Engineer needs to provide the following items on and/or prior to meeting:

1. Copy of Executed Construction Contract.
2. Copy of Sealed set of Construction Sheets (Plans).

Once Pre-Construction Meeting has been done, the Project Engineer needs to provide the following items to Financial Accounting within 10 days:

1. Minutes of the meeting.
2. Notice to proceed on letterhead. (Exh. 1)
3. List of materials to be provided by District. If none, list vendors and subcontractors to be utilized by contractor.
4. Copy of Sign-In sheet.

### Construction in Progress:

As construction progresses, the following items are required with all Application for Payment Requests:

1. Application for Payment with Project Engineer's Certification. (Exh.2)
2. TxDOT Form 252-Contract Time Statement certified by Project Engineer per payment request. (Exh.3)
3. Schedule of values certified by Project Engineer per payment request. (Exh.4)
4. Estimate Quantity up-to-date worksheet of material on hand per payment request, if applicable. All Material-On-Hand will be stored at District's Yard and/or District owned facilities. (Exh.5)
5. Monthly update of new vendors and subcontractors not included on Pre-Construction Meeting list.
6. Partial Waiver(s) of Lien from all suppliers and/or subcontractors, starting from 2<sup>nd</sup> Payment Request as noted on General Conditions Ch.14.02, A(2). (Exh.6)

(Continued)

7. Certified Payroll Reports with approved wage classifications for billed work periods are required from Notice to Proceed up to completion. If no work was done for a specific billing period, please state "No Work Done" on the Certified Payroll Reports.
8. Copies of Approved Change Orders (Exh.7), Notice to Suspend (Exh.8) and Notice to Resume Work (Exh.9), if applicable, certified by Project Engineer. Make sure detailed support documentation is attached.

**Substantial Completion:**

Once contractor certifies the structure and has met requirements to use and/or for occupancy, the following items are required:

1. Provide Written Notice received by Project Engineer from contractor advising project is substantially complete.
2. Provide Certificate of Substantial Completion detailing pending items on punch list. Items should be certified by Project Engineer. (Exh. 10)

**Completion of Project:**

Once project is complete, the following items found in the Exhibits section of the Construction Contract will be required to close out project:

1. Certificate of Completion certified by Project Engineer. (Exh. 11)
2. General Contractor's Warranty. (Exh. 12)
3. Final Contractor's Affidavit of Debts & Claims. (Exh. 13)
4. Final Contractor's Affidavit of Release (Waiver) of Liens from all suppliers and sub-contractors. (Exh.14)
5. Consent of Surety to Final Payment. (Exh. 15)
6. Sealed Copy of As-Builts.

**Payment Deadlines:**

1. Construction Payment Requests require Board approval. Submit complete package two weeks before the next available agenda. This will provide ample time for the District's engineering staff and Accounting Department to review and audit items for Agenda inclusion.
2. Payment will be issued Tuesdays after Board Approval.



## NOTICE TO PROCEED

PROJECT NAME: \_\_\_\_\_

PROJECT LOCATION: \_\_\_\_\_

CONTRACT AMOUNT: \_\_\_\_\_

CONTRACT NUMBER: \_\_\_\_\_

WAGE DECISION: \_\_\_\_\_

This is to inform you that \_\_\_\_\_, located  
\_\_\_\_\_ may proceed with the construction of the above referenced  
project covered by the terms of contract \_\_\_\_\_ effective the  
\_\_\_\_\_ day of \_\_\_\_\_ 20\_\_\_\_. According to the terms of the above-mentioned contract, you have  
ten (10) days to initiate work. After the ten (10) day period, the construction period for this project will be  
\_\_\_\_\_ ( ) consecutive calendar days. Please review and abide by the construction plan's "General  
Notes" prior to commencing with work.

\_\_\_\_\_  
Raúl E. Sesein, P.E., CFM  
General Manager

CC: Jaime Salazar, District Buyer  
Lora Briones, District's Financial Officer



APPLICATION FOR PAYMENT NO. \_\_\_\_\_

To: \_\_\_\_\_ (OWNER)  
From: \_\_\_\_\_ (CONTRACTOR)  
Contract: \_\_\_\_\_  
Project: \_\_\_\_\_  
Owner's Contract No. \_\_\_\_\_ Engineer's Project No. \_\_\_\_\_  
For Work accomplished through the date of: \_\_\_\_\_

- 1. Original Contract Price: \_\_\_\_\_
- 2. Net change by Change Order and Written Agreements (+or-): \_\_\_\_\_
- 3. Current Contract Price (1 plus 2): \_\_\_\_\_
- 4. Total completed and stored to date: \_\_\_\_\_
- 5. Retainage (per Agreement): \_\_\_\_\_
  - \_\_\_\_\_ % of completed Work: \_\_\_\_\_
  - \_\_\_\_\_ of stored material: \_\_\_\_\_
  - Total Retainage: \_\_\_\_\_
- 6. Total completed and stored to date less retainage (4 minus 5) \_\_\_\_\_
- 7. Less previous Application for Payments: \_\_\_\_\_
- 8. AMOUNT DUE THIS APPLICATION (6 MINUS 7) \_\_\_\_\_

Accompanying Documentation:

**CONTRACTOR'S CERTIFICATION:**  
The undersigned Contractor certifies that to the best of the Contractor's knowledge, information and belief the Work covered by this Application for Payment has been completed in accordance with the Contract Documents, that all amounts have been paid by the Contractor for Work for which previous Certificates for Payment were issued and payments received from the Owner, and that current payment shown therein is now due.

**CONTRACTOR:**  
  
BY: \_\_\_\_\_  
  
State of \_\_\_\_\_  
County of \_\_\_\_\_  
Subscribed and sworn to before me this \_\_\_\_\_ day of \_\_\_\_\_  
  
**Notary Public**  
My Commission expires: \_\_\_\_\_

**CERTIFICATE FOR PAYMENT:**  
In accordance with Contract Documents, based on on-site observations and the data comprising application, the Engineer certifies to the Owner that to the best of the Engineer's knowledge, information and belief the Work has progressed as indicated, the quality of the Work is in accordance with the Contract Documents, and the Contractor is entitled to payment of the AMOUNT CERTIFIED.

AMOUNT CERTIFIED \$ \_\_\_\_\_

(Attach explanation if amount certified differs from the amount applied for. Initial all figures on this application and on the Continuation sheet that are changed to conform to the amount certified)

**ENGINEER:**  
  
By: \_\_\_\_\_ Date: \_\_\_\_\_  
Project Engineer

This Certificate is not negotiable. The AMOUNT CERTIFIED is payable only to the contractor named herein. Issuance, payment and acceptance of payment are without prejudice to any rights of the Owner of Contractor under this Contract.

**BOARD:**  
  
Board Of Director's Meeting: \_\_\_\_\_  
Ramon Garcia, Chairman of the Board





**Estimate Quantity Update Worksheet**

Colonia: \_\_\_\_\_  
 Roadway: \_\_\_\_\_  
 Control: \_\_\_\_\_  
 Project No: \_\_\_\_\_  
 County: \_\_\_\_\_  
 Est. No: \_\_\_\_\_  
 Work Type: Paving & Drainage  
 Limits: \_\_\_\_\_  
 From: \_\_\_\_\_  
 To: \_\_\_\_\_

Contractor: \_\_\_\_\_  
 Contract Price: \_\_\_\_\_  
 Work Done this Mo.: \_\_\_\_\_  
 % Complete: \_\_\_\_\_  
 Date Began: \_\_\_\_\_  
 Contract Time: 120  
 Time Charged: 90  
 % Time Used: 75.00%

ITEM NO.	DESCRIPTION	UNIT	PROJECT QTY	Unit Price	Project Amount	FIRST MONTH			SECOND MONTH			THIRD MONTH						
						MONTHLY QUANTITY	QTY to Date	Item Cost (Monthly)	MONTHLY QUANTITY	QTY to Date	Item Cost (Monthly)	MONTHLY QUANTITY	QTY to Date	Item Cost (Monthly)				
	(901) ADMINISTRATIVE																	
	(902) PRELIMINARY ENGINEERING																	
	(903) CONSTRUCTION ENGINEERING																	
	(904) RIGHT-OF-WAY																	
	(905) ROADWAY CONSTRUCTION																	
	(906) DRAINAGE																	

Total to Date	Roadway (905):	\$0.00	Monthly Totals:	\$0.00	\$0.00	0.00
	Drainage (906):	\$0.00	ADMINISTRATIVE (901)			
	Total	\$0.00	PRELIMINARY ENGINEERING (902)			
			CONSTRUCTION ENGINEERING (903)			
			RIGHT-OF-WAY (904)			
			Roadway (905):	\$0.00	\$0.00	0.00
			Drainage (906):	\$0.00	\$0.00	0.00

Prepared and Checked By: \_\_\_\_\_  
 Signature: \_\_\_\_\_  
 Printed Name: \_\_\_\_\_  
 Date: \_\_\_\_\_





**PARTIAL/FINAL WAIVER OF LEIN**

THE STATE OF TEXAS

COUNTY OF \_\_\_\_\_

The undersigned contracted with \_\_\_\_\_  
\_\_\_\_\_ to furnish \_\_\_\_\_  
in connection with certain improvements to real property located in \_\_\_\_\_  
County, Texas, and owned by \_\_\_\_\_  
Which improvements are described as follows:

\_\_\_\_\_  
\_\_\_\_\_  
\_\_\_\_\_

In consideration of Pay Estimate No \_\_\_\_\_ in the amount of \_\_\_\_\_  
\_\_\_\_\_ DOLLAR(\$ \_\_\_\_\_) and other good and  
valuable consideration, the receipt and sufficiency of which is hereby acknowledged and  
confessed, the undersigned does hereby waive and release any mechanic's lien or materialmen's  
lien or claims of lien that the undersigned has or hereafter has on the above mentioned real  
property on account of any labor performed or materials furnished or to be furnished or labor  
performed and materials furnished by the undersigned pursuant to the above-mentioned contract  
or any constitutional lien that the undersigned may have.

Undersigned hereby guarantees that all bids for labor performed and/or materials furnished in the  
erection and construction of such improvements on the Property have been fully paid and  
satisfied and Undersigned does further guarantee that if for any reason a lien or liens are filed for  
material or labor against said Property arising out of any bills for material or labor in connection  
with the erection or construction of said improvements thereon, Undersigned will obtain a  
settlement of such lien or liens and a proper release thereof shall be obtained.

\_\_\_\_\_  
CONTRACTOR

BY: \_\_\_\_\_  
TITLE

SWORN TO AND SUBSCRIBED BEFORE ME, on this the \_\_\_\_\_ day of \_\_\_\_\_, 20\_\_ to  
certify which witness my hand and seal of office.

\_\_\_\_\_  
NOTARY PUBLIC in and for the State of Texas

My Commission Expires: \_\_\_\_\_



CHANGE ORDER NO. \_\_\_\_\_ (\_\_\_\_)

Project: \_\_\_\_\_

DATE OF ISSUANCE: \_\_\_\_\_ EFFECTIVE DATE: \_\_\_\_\_

OWNER: \_\_\_\_\_  
OWNER'S CONTRACT NO: \_\_\_\_\_

CONTRACTOR: \_\_\_\_\_ ENGINEER: \_\_\_\_\_  
\_\_\_\_\_  
\_\_\_\_\_

You are directed to make the following changes in the Contract Documents.

Description: 1. \_\_\_\_\_  
2. \_\_\_\_\_  
3. \_\_\_\_\_  
4. \_\_\_\_\_  
5. \_\_\_\_\_  
6. \_\_\_\_\_

Reason for Change Order: 1. \_\_\_\_\_  
2. \_\_\_\_\_  
3. \_\_\_\_\_  
4. \_\_\_\_\_  
5. \_\_\_\_\_  
6. \_\_\_\_\_

Attachments:

CHANGE IN CONTRACT PRICE:		CHANGE IN CONTRACT TIME:
Original Contract Price		Original Contract Time for
\$ 0.00		Substantial Completion: _____ calendar days or dates
Net Changes from previous Change Order		Net Change from previous Change Orders
\$ 0.00		0 calendar days
Contract Price prior to this Change Order		Contract Time prior to this Change Order
\$ 0.00		Substantial Completion: _____ calendar days or dates
Net Increase(decrease) of this Change Order		Net Increase(decrease) of this Change Order
\$ 0.00		0 calendar days
Contract Price with all approved Change Orders	Net % increase(decrease) from original contract price. #DIV/O! %	Contract Time with all approved Change Orders
\$ 0.00		Substantial Completion: _____ calendar days or dates

RECOMMENDED:  
By: \_\_\_\_\_  
Engineer (Authorized Signature)

APPROVED:  
By: \_\_\_\_\_  
Owner (Authorized Signature)

ACCEPTED:  
By: \_\_\_\_\_  
Contractor (Authorized Signature)

Date: \_\_\_\_\_

Date: \_\_\_\_\_

Date: \_\_\_\_\_



<b>NOTICE TO SUSPEND, WORK ORDER</b>		OWNER:
		PROJECT NAME:
		PROJECT:
		NAME AND ADDRESS OF CONTRACTOR:
ORDER NUMBER:		
DATE ISSUED:		

**THIS IS YOUR NOTICE TO SUSPEND, WORK ON THE CONTRACT AS NOTED.**

**SUSPENSION OF WORK**

You are to suspend work for the following reason(s): lead time to manufacture Slide gate.

Effective close of business:

Type of Suspension  Total  Partial

No Charge will be made against contract time for period of suspension.

Full count of contract time will continue.

An equitable adjustment of contract time will be made for period of partial suspension upon resumption work.

The Contractor shall, effective immediately, cease to issue any further orders and/or subcontracts for materials or services of this Contract. The Contractor shall immediately comply with this order and take all reasonable steps to minimize the incurrence of cost allocable to the work covered by this during the period of work stoppage.

**DO NOT RESUME WORK UNTIL YOU ARE NOTIFIED TO DO SO IN WRITING**



<b>NOTICE TO SUSPEND, OR RESUE WORK ORDER</b>		OWNER:	
		PROJECT NAME:	
		PROJECT:	
		NAME AND ADDRESS OF CONTRACTOR:	
ORDER NUMBER:	DATE ISSUED:		
<b>THIS IS YOUR NOTICE TO SUSPEND, OR RESUME WORK ON THE CONTRACT AS NOTED.</b>			
<b>RESUMPTION OF WORK</b>			
Effective Beginning of Business: _____ New Contract ending Date: _____			
Time changed during period or partial suspension _____ calendar days.			
SIGNATURE	TITLE	DATE	
PLEASE ACKNOWLEDGE RECEIPT BY RETURNING _____ COPY(S) TO _____			
SIGNATURE	TITLE	DATE	
<p><b>INSTRUCTIONS:</b>          If mailed to Contractor, send original by Certified Mail- Return Receipt Requested          If delivered in person, have Contractor sign the acknowledgement and retain the original.</p>			

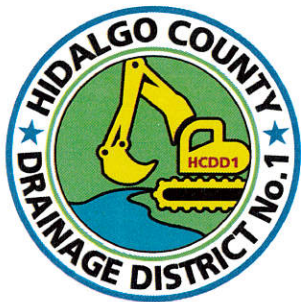

## Certificate of Substantial Completion

**PROJECT:**

**PROJECT NUMBER:**

**OWNER:**

**CONTRACTOR:**

The Work performed under this Contract has been reviewed and found, to the Engineer's best knowledge, information and belief, to be substantially complete. Substantial Completion is the stage in the progress of the Work when the Work or designated portion is sufficiently complete in accordance with the Contract Documents so that the owner can occupy or utilize the Work for its intended use. The date of Substantial Completion of the Project or portion designated above is the date of issuance established by this Certificate, which is also the date of commencement of applicable warranties required by the Contract Documents, except as stated below: Construction time is stopped at the day of Issuance.

Hidalgo County Planning Department  
Engineer

\_\_\_\_\_  
By: Raul E. Sesein, P.E.

\_\_\_\_\_  
Date of Issuance

A list of items to be completed or corrected is attached hereto. The failure to include any items on such list does not alter the responsibility of the Contractor to complete all Work in accordance with the Contract Documents. Unless otherwise agreed to in writing, the date of commencement of warranties for items on the attached list will be the date of issuance of the final Certificate of Payment or the date of final payment.

Cost estimate of Work that is incomplete or defective: \$ 0.

The Contractor will complete or correct the Work on the list of items attached hereto and complete the work by \_\_\_\_\_  
Date

\_\_\_\_\_  
Contractor

\_\_\_\_\_  
By

\_\_\_\_\_  
Date

The Owner accepts the Work or designated portion as substantially complete and will assume full possession at 5:00 a.m./p.m. on \_\_\_\_\_.

\_\_\_\_\_  
Date

\_\_\_\_\_  
Owner

\_\_\_\_\_  
By

\_\_\_\_\_  
Date

# Certificate of Substantial Completion

**PROJECT:**

**PROJECT NUMBER:**

**OWNER:**

**CONTRACTOR:**

**LIST OF ITEMS TO BE COMPLETED OR CORRECTED FOR THE ABOVE REFERENCED PROJECT.**

1. \_\_\_\_\_
2. \_\_\_\_\_
3. \_\_\_\_\_
4. \_\_\_\_\_
5. \_\_\_\_\_
6. \_\_\_\_\_
7. \_\_\_\_\_
8. \_\_\_\_\_
9. \_\_\_\_\_
10. \_\_\_\_\_

**PREPARED BY:**

**Hidago County Planning Dept.**  
**ENGINEER**

\_\_\_\_\_  
**BY: Raul E. Sesin, P.E.**

\_\_\_\_\_  
**DATE**



**CERTIFICATE OF CONSTRUCTION COMPLETION**

THIS IS TO CERTIFY THAT ON \_\_\_\_\_ DAY OF \_\_\_\_\_ A FINAL INSPECTION was made of the project herein described.

CONTRACT

\_\_\_\_\_  
CONTRACT DATE: \_\_\_\_\_  
OWNER: \_\_\_\_\_  
CONSTRUCTION CONTRACTOR: \_\_\_\_\_  
OF THE CITY OF \_\_\_\_\_ STATE OF \_\_\_\_\_

PROJECT DESCRIPTION

CONSTRUCTION OF \_\_\_\_\_

CONTRACT NO: \_\_\_\_\_  
Located in or near the City/Precinct Of \_\_\_\_\_

THIS IS TO CERTIFY”

1. That the work has been completed in accordance with the plans and specifications and all addenda, change orders, supplemental agreements thereto, and with the following exceptions:  
\_\_\_\_\_
2. That the sum of \_\_\_\_\_, deducted from the final payment of the Contractor is a fair and equitable settlement for the foregoing except work.
3. That the contractor has presented a “Certificate of Release” starting under oath, that all claims arising out of the performance of work have been fulfilled, and the Owner is released from all claims arising under or by virtue of said contract.
4. That the CONTRACTOR has presented in behalf of itself and its sureties, satisfactory evidence that it is bound to repair, replace, and make good any faulty workmanship and/or materials discovered in the work within a period of one year from this date, as provided in said contract.
5. Amount of Original Contract \_\_\_\_\_  
Present Amount of Contract \_\_\_\_\_

Total Amount of earned to Date \_\_\_\_\_  
Less: previous payments \_\_\_\_\_  
Balance \_\_\_\_\_  
Authorized deductions \_\_\_\_\_  
AMOUNTY OF FINAL PAYMENT \_\_\_\_\_

6. That the final payment in the amount of \_\_\_\_\_  
\_\_\_\_\_ is now due and payable.

\_\_\_\_\_  
Engineer's Signature

**CONCURRED BY:**

**CONCURRED BY:**

\_\_\_\_\_  
Contractor's Name

\_\_\_\_\_  
Hon. Ramon Garcia,

By: \_\_\_\_\_

Title: \_\_\_\_\_



## LETTER OF WARRANTY

Date: \_\_\_\_\_

Project Name: \_\_\_\_\_

Project Location: \_\_\_\_\_

Contract Number: \_\_\_\_\_

Contract Amount: \_\_\_\_\_

\_\_\_\_\_ warrants all labor performed and material installed at the above-mentioned job site, in accordance with the contract, drawings, specifications, alterations and additions thereto, for a period of (1) one year from date of installation. This warranty does not include normal wear and tear, and/or product abuse.

Under this warranty, \_\_\_\_\_ will be provided the opportunity to have one of its representatives assess any damage identified to be caused by employees and/or material installed by us. If said damage is judged to be the fault \_\_\_\_\_ workmanship and/or material, \_\_\_\_\_ will at no cost to the Owner repair or replace defective material.

Respectfully,

\_\_\_\_\_  
Name

Title

Contractor Company Name: \_\_\_\_\_





## Contractor's Affidavit of Release of Liens

<b>PROJECT:</b> <b>OWNER:</b> <b>CONTRACTOR:</b> <b>ENGINEER:</b>	<b>PROJECT NO.</b>
<p>The Contractor, in accordance with the Contract Documents, and in consideration for the full and final payment to the Contractor for all services in connection with the project, does hereby waive and release any and all liens, or any and all claims to liens which the Contractor may have on or affecting the project as a result of its contract(s) for the Project or for performing labor and/or furnishing materials in any way connected with the construction of any aspect of the project. The Contractor further certifies and warrants that all subcontractors of labor and/or materials for the Project, except as listed below, have been paid in full for all labor and/or materials supplied to, for through or at the direct or indirect request of the Contractor prior to, through and including the date of this affidavit.</p>	
<p><b>EXCEPTIONS:</b> (If none, write "NONE". The Contractor shall furnish a bond acceptable to the Owner for each exception.)</p>          	
<p><b>CONTRACTOR</b></p> <p>By _____</p> <p>Title _____</p> <p>Subscribed and sworn to before me this _____ day of _____</p> <p>Notary Public: _____</p> <p>My Commission Expires: _____</p>	



**CONSENT OF SURETY TO FINAL PAYMENT**

Project Name: \_\_\_\_\_

Project Location: \_\_\_\_\_

Contract Amount: \_\_\_\_\_

Contract Number: \_\_\_\_\_

Bond Number: \_\_\_\_\_

Contractor's Company Name: \_\_\_\_\_

In accordance with the provisions of the contract between the Owner and the Contractor as indicated above, the \_\_\_\_\_, Surety hereby approves of the Final Payment to the Contractor, and agrees that Final Payment to the Contractor shall not relieve the Surety of any of its obligations to Hidalgo County Drainage District No. 1 located at 902 N. Doolittle Road, Edinburg, TX 78542 as set forth in said Surety's Bonds.

IN WITNESS WHEREOF, the Surety has hereunto set its hand on this date: \_\_\_\_\_ day of \_\_\_\_\_, 20 \_\_\_\_\_.

**NOTARY**

\_\_\_\_\_  
(Surety)

Attest:

\_\_\_\_\_  
(Signature of Authorized Representative)

\_\_\_\_\_  
(Printed Name & Title)

(Seal):

\_\_\_\_\_  
Date

**AI -49950**

**8.**

**DRAINAGE DISTRICT**

Meeting Date: 06/02/2015

Submitted For: Raul Sesin

Submitted By: Claudette Guerrero,  
DRAINAGE DISTRICT

Department: DRAINAGE DISTRICT

---

Information

CAPTION

Discussion and possible action to require addition of sub-consultants, with supporting documentation, by supplemental agreement in accordance to Article 14-Subcontracting and Assignments for professional engineering services, to include sub consultant's labor rates.

BACKGROUND

---

Fiscal Impact

Attachments

backup

---

**Form Review**

<b>Inbox</b>	<b>Reviewed By</b>	<b>Date</b>
Budget & Management	Veronica Ortiz	05/29/2015 04:05 PM
Final Approval	Monica Badillo	05/29/2015 04:47 PM
Form Started By: Claudette Guerrero		Started On: 05/29/2015 03:55 PM
Final Approval Date: 05/29/2015		

# HIDALGO COUNTY DRAINAGE DISTRICT NO. 1

902 N. Doolittle Road Edinburg, TX 78542

(956)292-7080

Fax: (956)292-7084



To : All District Board Members  
From : Raul E. Sesin, P.E., CFM  
Date : May 29, 2015  
Subject : Supplemental Agreements-Sub Consultants Approval Process

---

On December 16, 2014, the Board took action under agenda Item No. 47733 to approve sub-consultants in the form of a letter. The District acknowledges extra work is required to meet milestones of its projects and recognizes a need by the assigned project engineers to add sub-consultants to its project team and in these instances the District wants to facilitate the approval for addition of sub-consultants by conforming to articles from the District's Agreements for Professional Engineering Services.

As Stated in the District's Master Agreement for Professional Engineering Services, Article 14-Subcontracting and Assignments, the Engineer shall not assign, subcontract or transfer the Engineer's interest in this agreement without the prior written consent of the owner and Engineer shall bind every sub-consultant by written subcontract to observe all the terms of the agreement to the extent that they may be applicable to each sub-consultant. And, Article 8-Supplemental Agreements, states the terms of the agreement may be amended by supplemental agreement.

Discussion and Action of the previously stated will be presented to the Board on June 16, 2015 to require the addition of sub-consultants with supporting documentation be made by supplemental agreement in accordance to Article 14-Subcontracting and Assignments.

Encl./

**Return**

SPECIAL MEETING - December 16, 2014

BE IT REMEMBERED, that on this 16th day of December A.D., 2014, there was begun and held a SPECIAL MEETING of the Honorable Commissioners' Court of Hidalgo County, Texas, wherein the following members thereof were present, to-wit:

HONORABLE RAMON GARCIA	HIDALGO COUNTY JUDGE
HONORABLE A.C. CUELLAR, JR.	COMMISSIONER, PRECINCT NO. 1
HONORABLE HECTOR "TITO" PALACIOS	COMMISSIONER, PRECINCT NO. 2
HONORABLE JOE M. FLORES	COMMISSIONER, PRECINCT NO. 3
HONORABLE JOSEPH PALACIOS	COMMISSIONER, PRECINCT NO. 4

and ARTURO GUAJARDO, JR., COUNTY CLERK & EX-OFFICIO CLERK OF THE COMMISSIONERS' COURT of Hidalgo County, Texas, wherein the following proceedings were had, to-wit:



**AGENDA  
DRAINAGE DISTRICT  
BOARD OF DIRECTORS  
December 16, 2014  
9:00 A.M.**

NOTICE is hereby given in accordance with Chapter 551, Texas Government Code, that a SPECIAL MEETING of the Drainage District #1 Board of Directors will be held at the Edinburg Council Chambers 415 W. University Drive, Edinburg, Hidalgo County, Texas. Discussion and possible action relating to the following business will be transacted:

1. **Roll Call**  
All members of the Board were counted present for the exception of Commissioner Joe Flores, but joined the meeting shortly after commencement.
2. **Open Forum**  
Godfrey Garza gave an update on a couple of developments. The Acosta Subdivision, west of Edinburg, is having water issues; water is being pumped out of the area and samples have been acquired. Sharyland Water Supply stated there had been a leak in the area and have since repaired it. He stated it appeared to have been an old dump site, but they will continue researching the area. He also briefed the Board in regards to FEMA's direction on the Penitas Pump House. The engineers will be preparing a cost estimate and will bring it back to the Board.
3. **Approval of Consent Agenda**  
The Board moved to approve the Consent Agenda.
4. **AI -47731** [Approval of Interlocal Agreement between Hidalgo County Drainage District No. 1 and County of Hidalgo \(LJ Drainage Project - 13 tracts - Project limits: From Cesar Chavez Rd. to Alamo Lateral Drain\)](#)

On motion by COMMISSIONER PCT. 4. JOSEPH PALACIOS, seconded by

COMMISSIONER PCT. 1, A.C. CUELLAR, JR., the Board made a UNANIMOUS vote of approval.

Vote: 4 - 0 - Unanimously

**Attachments:**

email legal

agrmt/executed

5. AI -47733 A.) Requesting approval of final negotiated Agreement for Professional Engineering Services with R. Gutierrez Engineering Corporation as it relates to Pct. 2- "Las Milpas Road Crossing South Floodwater Channel East of FM 907 (Alamo Road)". Approved for negotiations by HCDD1 Board of Directors on November 18, 2014.

On motion by COMMISSIONER PCT. 2, HECTOR "TITO" PALACIOS, seconded by COMMISSIONER PCT. 1, A.C. CUELLAR, JR., the Board made a UNANIMOUS vote of approval.

Vote: 4 - 0 -Unanimously

B.) Requesting approval of Work Authorization No. 1 with R. Gutierrez Engineering Corporation in the amount of \$16,416.00 as it relates to Engineering Services for Pct. 2 -" Las Milpas Road Crossing South Floodwater Channel East of FM 907 (Alamo Road)".

On motion by COMMISSIONER PCT. 1, A.C. CUELLAR, JR., seconded by COMMISSIONER PCT. 4, JOSEPH PALACIOS, the Board made a UNANIMOUS vote of approval.

Vote: 4 - 0 – Unanimously

C.) Requesting approval of Work Authorization No. 2 with R. Gutierrez Engineering Corporation in the amount of \$2,592.00 as it relates to Surveying Services for Pct. 2 - "Las Milpas Road Crossing South Floodwater Channel East of FM 907 (Alamo Road)".

On motion by COMMISSIONER PCT. 1, A.C. CUELLAR, JR., seconded by COMMISSIONER PCT. 4, JOSEPH PALACIOS, the Board made a UNANIMOUS vote of approval.

Vote: 4 - 0 – Unanimously

D.) Approval of subconsultant(s) of TEDSI Infrastructure Group for Phase II of the Master Drainage System for the design and expansion of the lateral drain outfall systems for Precinct No. 1 and Precinct No. 4 in accordance with that certain Agreement by and between Hidalgo County Drainage District No.1 and TEDSI Infrastructure Group dated the 23rd day of March, 2004.

Mr. Garza listed the subconsultants that TEDSI Infrastructure Group will use for Phase II of the Master Drainage System. They are as follows: L & G Engineering Laboratories, RGV Right of Way Services, LLC, Civil Systems Engineering, Inc., Quintanilla, Headley and Associates, Inc., Dos Logistics, and Valley Right of Way Consulting Services, LLC.

Commissioner Joe Flores joined the meeting.

Mr. Garza explained that under the current contract the prime contractor must advise the Board of the subconsultants they will hire on a project. Judge Garcia asked him if this procedure had been done before and Mr. Garza answered by stating that it has been done in different ways, sometimes in a form of a supplemental agreement, work authorization, or what is being done today. Judge Garcia was informed that Mr. Garza's family possibly had an interest in Valley Data Systems Services had that they done over a million dollars of work for the Drainage District as a subconsultant in 2007. Judge Garcia reminded Mr. Garza

that his contract requires him to advise the Board of any company he may have potential conflict of interest and asked him if he'd ever notified the Board. Mr. Garza stated that if there were conflict of interest, he will review it with the Board. He also stated that the Board may request the prime contractor to provide them with the information regarding the subconsultant, Valley Data Systems, in regards to work done for the District.

On motion by COMMISSIONER PCT. 1, A.C. CUELLAR, JR., seconded by COMMISSIONER PCT. 4, JOSEPH PALACIOS, the Board made a UNANIMOUS vote of approval.

Vote: 5 - 0 - Unanimously

### **2013 BOND SERIES**

E.) Approval of subconsultant(s) of TEDSI Infrastructure Group for Precinct 1 2012 Bond Referendum Improvement Projects in accordance with that certain Agreement by and between Hidalgo County Drainage District No.1 and TEDSI Infrastructure Group dated the 9th day of April, 2013.

On motion by COMMISSIONER PCT. 1, A.C. CUELLAR, JR., seconded by COMMISSIONER PCT. 3, JOE M. FLORES, the Board made a UNANIMOUS vote of approval.

Vote: 5 - 0 - Unanimously

F.) Requesting approval of Supplemental Agreement No. 2 to Work Authorization No. 4A with TEDSI Infrastructure Group in the amount of \$5,125.98 as it relates to Material Testing for Monte Cristo Drain Control Structure, Pct. 1 - 2012 Bond Referendum Improvement Projects.

On motion by COMMISSIONER PCT. 1, A.C. CUELLAR, JR., seconded by COMMISSIONER PCT. 3, JOE M. FLORES, the Board made a UNANIMOUS vote of approval.

Vote: 5 - 0 - Unanimously

G.) Requesting approval of Supplemental Agreement No. 2 to Work Authorization No. 4B with TEDSI Infrastructure Group in the amount of \$6,394.50 as it relates to Material Testing for Weslaco North Lateral Control Structure, Pct. 1 - 2012 Bond Referendum Improvement Projects.

On motion by COMMISSIONER PCT. 3, JOE M. FLORES, seconded by COMMISSIONER PCT. 4, JOSEPH PALACIOS, the Board made a UNANIMOUS vote of approval.

Vote: 5 - 0 - Unanimously

H.) Requesting approval of Work Authorization No. 17 with TEDSI Infrastructure Group in the amount of \$24,507.85 as it relates to Material Testing and Construction Management required for Pct. 1 Spanish Palms Outfall Improvements, Pct. 1 - 2012 Bond Referendum Improvement Projects.

On motion by COMMISSIONER PCT. 3, JOE M. FLORES, seconded by COMMISSIONER PCT. 4, JOSEPH PALACIOS, the Board made a UNANIMOUS vote of approval.

Vote: 5 - 0 - Unanimously

I.) Requesting approval of Supplemental Agreement No. 3 with L&G Engineering to Agreement for Professional Services Pct. 3 - "La Joya Watershed Improvement Project" amendment of Project Team.

Mr. Garza noted a correction to the Agreement Number; it should read Supplemental Agreement No. 2.

On motion by COMMISSIONER PCT. 1, A.C. CUELLAR, JR., seconded by COMMISSIONER PCT. 4, JOSEPH PALACIOS, the Board made a UNANIMOUS vote of approval with correction.

Vote: 5 - 0 – Unanimously

**Attachments:**

TEDSI SA No. 2 to WA No.4A

TEDSI SA No. 2 to WA No. 4B

TEDSI WA No. 17 Spanish Palms

TEDSI letter subs Phase II MDS

TEDSI letter subs Pct.1 2012 Bond

R. Gutierrez Agreement Las Milpas

L&G SA No. 3 LJWS

WA No. 1 Las Milpas

WA No. 2 Las Milpas

6. AI -47761 Requesting approval of Work Authorization No. 15 in the amount of \$229,500.00 to Agreement for Professional Services Phase II of the Master Drainage System for the design and expansion of the lateral drain outfall systems for Precinct No. 1 and Precinct No. 4 with TEDSI Infrastructure Group as it relates to FEMA Mapping Activity Statement No. 3 for Approximately 25.5 Miles of HCDD1 Master Drainage System.

On motion by COMMISSIONER PCT. 3, JOE M. FLORES, seconded by COMMISSIONER PCT. 4, JOSEPH PALACIOS, the Board made a UNANIMOUS vote of approval.

Vote: 5 - 0 - Unanimously

**Attachments:**

TEDSI WA No. 15 Phase II MDS

7. AI -47775 2013 Bond Payments:  
Request to issue manual payment once review and audit procedures are complete on the following items:

A. Request for Payment No. 1-RDH Site & Concrete, LLC in the amount of \$220,448.45 related to Construction Contract No. HCDD1-14-010-05-06 Pct.2 Rural Drainage Development -Seminole Valley Subdivision Area. PO# 625110.

On motion by COMMISSIONER PCT. 4, JOSEPH PALACIOS, seconded by COMMISSIONER PCT. 1, A.C. CUELLAR, JR., the Board made a UNANIMOUS vote of approval.

Vote: 5 - 0 - Unanimously

B. Request for Payment No. 4-Texas Cordia Construction, LLC in the amount of \$9,117.00 related to Construction Contract No. HCDD1-14-004-02-11 Pct.4 Edinburg Drain Stub-Out to South Main Drain Control Structure. PO#624505.

On motion by COMMISSIONER PCT. 1, A.C. CUELLAR, JR., seconded by COMMISSIONER PCT. 4, JOSEPH PALACIOS, the Board made a UNANIMOUS vote of approval.

Vote: 5 - 0 – Unanimously

C. Request for Payment Final Payment from GP7 Construction, Inc in the amount of \$8,857.63 related to Construction Contract No. HCDD1-13-021-04-29A- Pct.2 Rural Drainage Development FM 495 Drain Trenton Road Field Crossing. PO#624901.

On motion by COMMISSIONER PCT. 1, A.C. CUELLAR, JR., seconded by COMMISSIONER PCT. 4, JOSEPH PALACIOS, the Board made a UNANIMOUS vote of approval.

Vote: 5 - 0 – Unanimously

**Attachments:**

11-26-14-TxCordia Pmt#4 Approval

12-02-14\_RDH PMT#1 Approval

12-10-14-GP7 PMT#4-FINAL Approval

GP7-PMT#4-FINAL

RDH PMT#1-Seminole Subd

Texas Cordia Pmt#4-Edinburg Stub

8. AI -47825 A. Requests approval for budget amendment from District's General Fund in the amount of \$200,000.00 to fund Pct.2 Las Milpas Road Crossing South Floodwater Channel East of FM 907 (Alamo Road) Project.

On motion by COMMISSIONER PCT. 1, A.C. CUELLAR, JR., seconded by COMMISSIONER PCT. 3, JOE M. FLORES, the Board made a UNANIMOUS vote of approval.

Vote: 5 - 0 - Unanimously

B. Request approval for budget amendment from District's General Fund in the amount of \$229,500.00 to fund WA#15-Fema Mapping Activity Statement No. 3 for approximately 25.5 Miles from Agreement for Professional Engineering Services MDS Ph.2-Laterals Pct. 1&4, BOD 03-23-2004.

On motion by COMMISSIONER PCT. 3, JOE M. FLORES, seconded by COMMISSIONER PCT. 1, A.C. CUELLAR, JR., the Board made a UNANIMOUS vote of approval.

Vote: 5 - 0 - Unanimously

9. AI -47838 A. Discussion and approval of the job description for the position of Assistant General Manager.  
B. Discussion and approval of salary for Assistant General Manager position.  
C. Authorization to create Assistant General Manager position with appropriate slot number.  
D. Approval to authorize Financial Officer to identify and allocate appropriate funding.  
E. Approval to revise salary schedule.

NO ACTION on Items A - E.

10. AI -47808 Presentation of 2014 Drainage District Tax Roll

On motion by COMMISSIONER PCT. 3, JOE M. FLORES, seconded by COMMISSIONER PCT. 1, A.C. CUELLAR, JR., the Board made a UNANIMOUS vote of approval.

Vote: 5 - 0 - Unanimously

**Attachments:****DR1 Tax Roll**

11.

**Closed Session:**

Board of Directors may go into Closed Session pursuant to Chapter 551, Texas Government Code, Sections 551.071, 551.072 & 551.074 to discuss the following:

*NO ACTION taken on this Item.*

A.

**Real Estate Acquisition**

B.

**Pending and/or Potential Litigation**

C.

AI -47726

**Reassignment of duties of Financial Officer, Accountant and/or Contracts Manager/Accounts Payable Clerk**

*NO ACTION taken on Items 11.A - 11.C.*

12.

**Open Session:**

A.

**Real Estate Acquisition**

B.

**Pending and/or Potential Litigation**

C.

AI -47727

**Reassignment of duties of Financial Officer, Accountant and/or Contracts Manager/Accounts Payable Clerk**

*NO ACTION taken on Items 12.A - 12.C.*

13.

**Closed Session:**

Board of Directors may reconvene into Closed Session for the discussion regarding the agenda items listed

*NO ACTION taken on this Item.*

14.

**Open Session:**

Board of Directors may reconvene into Open Session for the discussion regarding the agenda items listed

*NO ACTION taken on this Item.*

15.

**Adjourn**

On motion by COMMISSIONER PCT. 3, JOE M. FLORES, seconded by COMMISSIONER PCT. 1, A.C. CUELLAR, JR., the Board made a UNANIMOUS vote of approval.

**Vote: 5 - 0 - Unanimously**

There being no further business to come before said Court, the meetings of the Commissioners' Court and the Drainage District #1 Board are now hereby adjourned.

Dated this the 16th day of December, 2014

ARTURO GUAJARDO, JR., County Clerk  
Hidalgo County, Texas

By: \_\_\_\_\_  
Virginia Jones, Deputy

I, ARTURO GUAJARDO, JR., County Clerk attest that this is an accurate accounting of a proceeding of the Commissioners' Court held on December 16, 2014.

Signed this 16th day of December 2014

ATTEST:  
ARTURO GUAJARDO, JR.  
County Clerk and Ex-Officio Clerk  
Of the Commissioners' Court of  
Hidalgo County

By: \_\_\_\_\_  
(Seal) Virginia Jones, Deputy



# TEDSI INFRASTRUCTURE GROUP

*Consulting Engineers*

1201 E. Expressway 83 ♦ Mission, Texas 78572

December 8, 2014

Mr. Godfrey Garza, Jr. CFM  
District Manager  
Hidalgo County Drainage District No. 1  
902 N. Doolittle Road  
Edinburg, Texas 78539

**RE: *Subconsultants utilized for Pct.1-2012 Bond Referendum Improvement Project***

Dear Mr. Garza:

We would like to inform you of the subconsultants used under the various Work Authorizations on the Pct. 1-2012 Bond Referendum Improvement Project that were not included in the original contracts.

**Pct.1-2012 Bond Referendum Improvement**

HNTB

Beatly Bangle Strama, LP

Bickerstaff Heath Delgado Acosta, LLP

Quintanilla Headley & Associates

AMTEST

RGV Right-of-Way Services, LLC.

University of Texas-Pan American

Should you have any questions, please do not hesitate to contact me at the office.

Thank you,

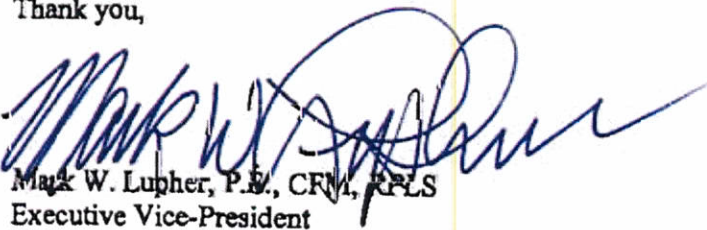

Mark W. Luper, P.E., CFM, RPLS  
Executive Vice-President



# TEDSI INFRASTRUCTURE GROUP

*Consulting Engineers*

1201 E. Expressway 83 ♦ Mission, Texas 78572

December 8, 2014

Mr. Godfrey Garza, Jr. CFM  
District Manager  
Hidalgo County Drainage District No. 1  
902 N. Doolittle Road  
Edinburg, Texas 78539

**RE: *Subconsultants utilized for Phase II of the MDS for the design and expansion of the Lateral Drain Outfall Systems for Precinct No. 1 and No. 4 Project***

Dear Mr. Garza:

We would like to inform you of the subconsultants used under the various Work Authorizations on the Phase II of the MDS for the design and expansion of the Lateral Drain Outfall Systems for Precinct No. 1 and No. 4 that were not included in the original contracts.

**Phase II of the MDS for the design and expansion of the Lateral Drain Outfall Systems for Precinct No. 1 and No. 4**

- L&G Engineering Laboratory
- RGV Right-of-Way Services, LLC.
- Civil Systems Engineering, Inc.
- Quintanilla, Headley & Associates, Inc.
- Dos Logistics
- Valley Right of Way Consulting Services, LLC.

Should you have any questions, please do not hesitate to contact me at the office.

Thank you,

Mark W. Lupton, P.E., CFM, RPLS  
Executive Vice-President

**AI -49951**

**9. C.**

**DRAINAGE DISTRICT**

Meeting Date: 06/02/2015

Submitted By: Monica Badillo,  
EXECUTIVE OFFICE

Department: EXECUTIVE OFFICE

---

Information

CAPTION

Pending/Potential Litigation:

Discussion of report submitted by the Lee Law Firm regarding their review, report and recommendations concerning the Agreement between Hidalgo County Drainage District No. 1 and Integ Corporation.

BACKGROUND

---

Fiscal Impact

Attachments

*No file(s) attached.*

---

**Form Review**

<b>Inbox</b>	<b>Reviewed By</b>	<b>Date</b>
Budget & Management	Veronica Ortiz	05/29/2015 04:02 PM
Final Approval	Monica Badillo	05/29/2015 04:47 PM
Form Started By: Monica Badillo		Started On: 05/29/2015 03:59 PM
Final Approval Date: 05/29/2015		

AI -49952

10. C.

**DRAINAGE DISTRICT**

**Meeting Date:** 06/02/2015

**Submitted By:** Monica Badillo,  
EXECUTIVE OFFICE

**Department:** EXECUTIVE OFFICE

---

**Information**

**CAPTION**

Pending/Potential Litigation:

Discussion, consideration and possible action related to the report submitted by the Lee Law Firm regarding their review, report and recommendations concerning the Agreement between Hidalgo County Drainage District No. 1 and Integ Corporation.

**BACKGROUND**

---

**Fiscal Impact**

**Attachments**

*No file(s) attached.*

---

**Form Review**

<b>Inbox</b>	<b>Reviewed By</b>	<b>Date</b>
Budget & Management	Veronica Ortiz	05/29/2015 04:05 PM
Purchasing Department	Monica Badillo	05/29/2015 04:47 PM
Form Started By: Monica Badillo		Started On: 05/29/2015 04:01 PM
Final Approval Date: 05/29/2015		